

FVRE11S SERIES

FUJI INVERTERS

Powerful and compact inverters
with dynamic torque-vector control



P

owerful, compact inverters supported by cuttingedge technology. Dynamic torque-vector control promises optimum motor control.

- Even with a compact body size, this series has a high starting torque of 200% at 0.5Hz and motor wow in the low speed range is suppressed to approximately half that of conventional inverters.
- Equipped with intelligent functions such as automatic energy-saving, PID control, auto-tuning, and RS485 communication, and enhanced maintenance/protection functions such as inrush-current suppression and lifetime early warning.



1. Dynamic torque-vector control

Dynamic torque-vector control system performs high-speed calculation to determine the required motor power for the load status. Our exclusive technology promises optimal control of voltage and current vectors for maximum output torque.

- **High starting torque of 200% at 0.5Hz**
Securely used for heavy load such as conveyance of lifting and traversing.
Also available for the second motor by changeover operation.

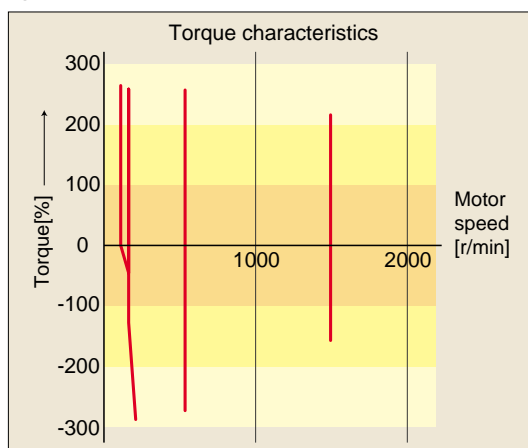

E11S

● Trip-free operation

The remarkably improved current limiting function (Automatic deceleration, stall prevention) provides continuous stable operation even for an impact load.

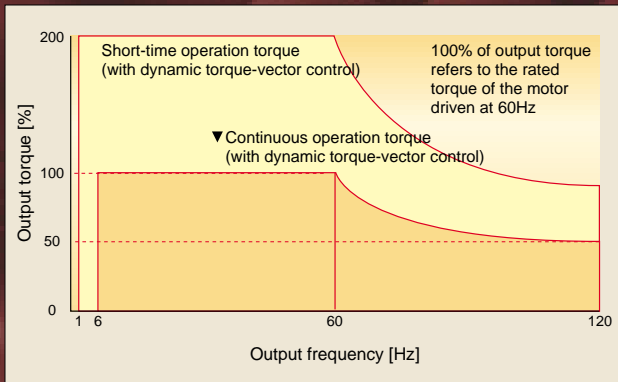

※ The above graph shows an example of torque characteristics when combining FVR-E11S (at dynamic torque-vector control) with Fuji standard three-phase motor (8-type series, 4 poles). Continuous operation torque is for limits of allowable load torque for using the motor within the allowable temperature range and is not for motor output torque. The motor output torque is shown by the short-time operation torque.

● Reduced motor wow at low speed

Fuji's unique On-Delay compensation method reduces motor wow at low speed to approximately half of that of conventional inverters.

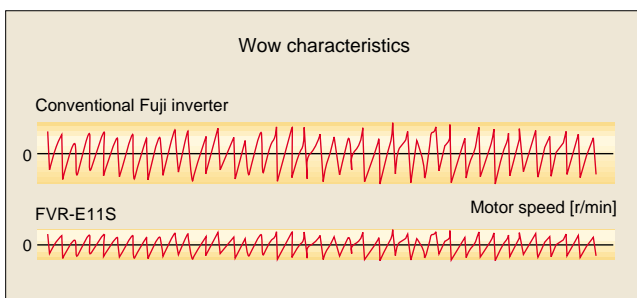

2. Compact



● Miniaturization of minimum level in the class

Compared to the conventional FVR-E9S series, the volume is reduced to approximately 70%. (three-phase 200V, 0.75kW).

● Uniform height dimension

All models up to 3.7kW have a uniform height of 130mm, which makes it easy to design panels.



● Braking resistor connectable to all models

Owing to a built-in braking transistor, an optional braking resistor can be installed to increase the regenerative braking capacity for conveyance and transportation machines that require large braking power.

3. Consideration for peripheral devices



- **Built-in inrush-current suppression circuit as standard**

The capacity of peripheral devices such as magnetic contactor can be minimized.

- **Low noise**

Remarkably reduces influence to devices such as sensors.

- **Equipped with a terminal for connecting DC REACTOR for harmonics suppression**

- **Minimal motor sound driving with higher carrier frequency setting**

- **Selectable control meter outputs (analog/pulse changeover)**

- **24V power source for transistor output**

4. Advanced, convenient functions



- **Equipped automatic energy-saving function as standard**

Since controlling the motor losses to minimum, realizes further electric power-saving.

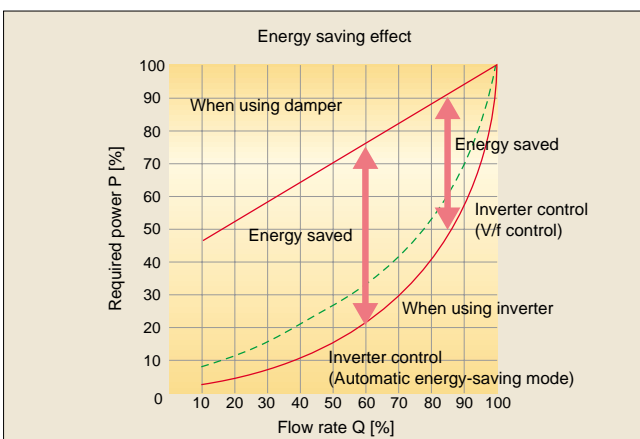

- **New on-line tuning system**

On-line tuning to continuously check for variation of motor characteristics during running for high-precision speed control.

This tuning function also available for a second motor, which allows high-precision driving of the second motor by changeover operation between two motors.

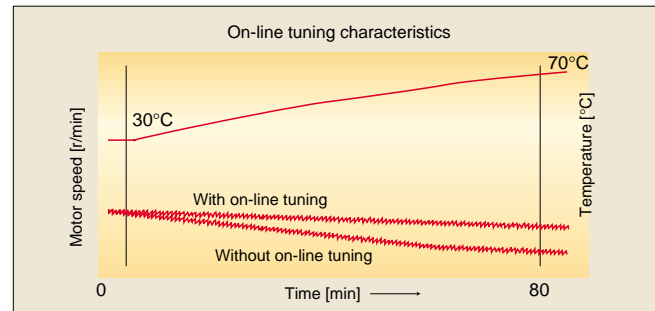

- **Continuous operation after momentary power failure**

Provided with restart mode setting; restart either at output frequency on power failure occurrence or at starting frequency.

- **PID control function**

Equipped with a PID control function which can control the flow rate of fans and pumps in an optimal manner.

- **Various frequency setting methods**

- Keypad operation or analog input (4 to 20mA_{dc}, 0 to +5V_{dc}, 0 to ±10V_{dc}, normal/inverse)
- Multistep speeds, 16-step setting (0 to 15 steps) and UP/DOWN control etc.

- **Equipped with RS485 interface as standard**

5. Wide variation



- **Line-up up to 7.5kW**
Extensively arranged three-phase 200V and 400V series, facilitating the unification of applying inverters to machines and equipment.

- **Single-phase 200V series (2.2kW or smaller)**

- **Various indications on the keypad panel**
Indicates output frequency, output current, output voltage, motor speed, trip history, etc.



- **Simple wiring**
Only requires removing covers of the main circuit and control circuit terminal blocks adopting screw terminal, without detaching the keypad panel.

- **Simple function setting by copy unit (Option)**
The optional copy unit (CP-E11S) can set functions in plural inverters in a lump, which can be commonly used for FUJI's C11S series.

6. Protective functions, Maintenance



- **Indication of main circuit capacitor life and accumulated operation time**

- Cooling fan stop operation possible
- Overheat early warning of heat sink
- Protective function of input/output phase loss

8. Global products



- **Conforms to major world safety standards: UL, cUL, TÜV, EN (CE marking)**

- **Complied with EMC Directive (Emission) when connected to optional EMC compliance filter**
- **Connection to field bus: Profibus-DP, Interbus-S, DeviceNet, Modbus Plus, CAN Open (Option)**

7. Easy operation and wiring



- **Simple remote control**
Remote control is available by removing keypad panel and using an optional extension cable (CBR-5S).

keypad panel and using an optional extension cable (CBR-5S).

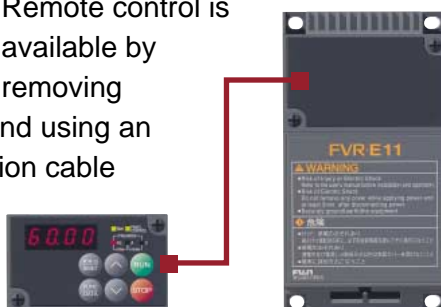

EU region		North America/Canada	
CE	TÜV Rheinland BAUART GEPRÜFT TYPE APPROVED	UL US LISTED	
EU Directive (CE marking) TÜV approval		UL, cUL	

Wide range of inverters: single-phase 200V, three-phase 400V, and three-phase 200V.

Nominal applied motors [kW]	Single-phase 200V series	Three-phase 400V series	Three-phase 200V series
0.1	FVR0.1E11S-7JE		FVR0.1E11S-2JE
0.2	FVR0.2E11S-7JE		FVR0.2E11S-2JE
0.4	FVR0.4E11S-7JE	FVR0.4E11S-4JE	FVR0.4E11S-2JE
0.75	FVR0.75E11S-7JE	FVR0.75E11S-4JE	FVR0.75E11S-2JE
1.5	FVR1.5E11S-7JE	FVR1.5E11S-4JE	FVR1.5E11S-2JE
2.2	FVR2.2E11S-7JE	FVR2.2E11S-4JE	FVR2.2E11S-2JE
3.7		FVR3.7E11S-4JE	FVR3.7E11S-2JE
5.5		FVR5.5E11S-4JE	FVR5.5E11S-2JE
7.5		FVR7.5E11S-4JE	FVR7.5E11S-2JE

How to read the model number

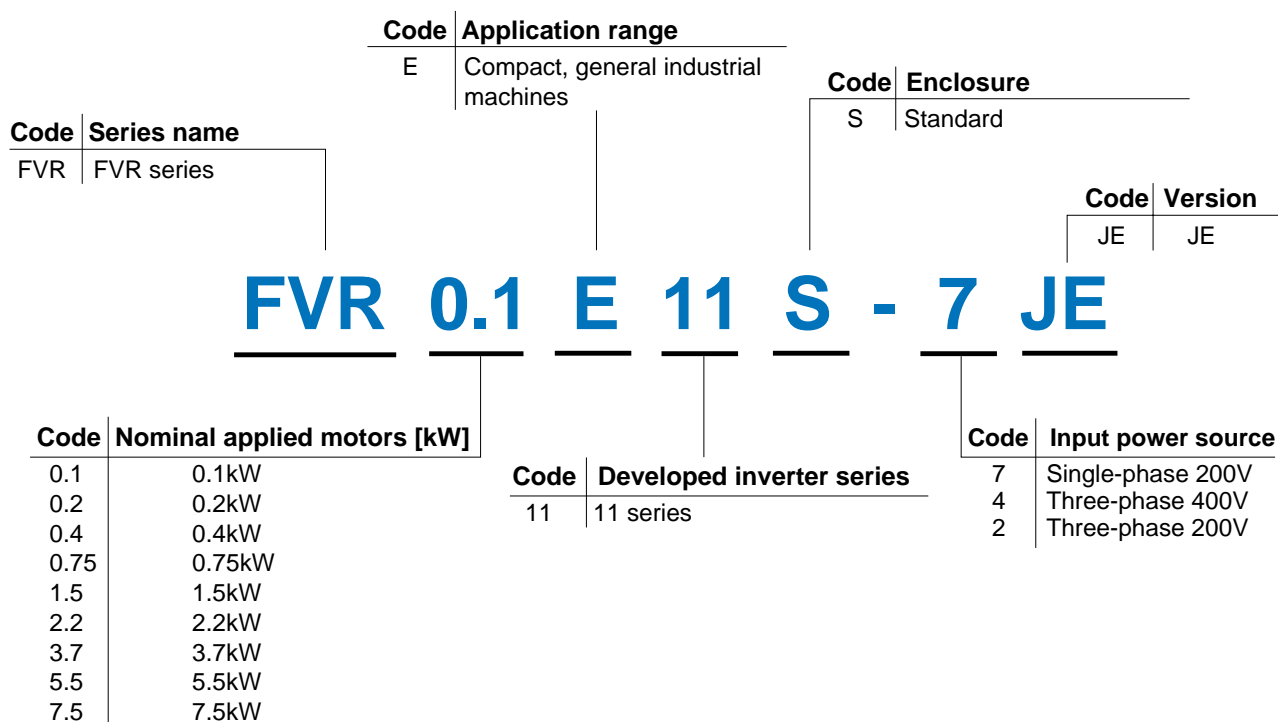

FVR-E11S series. For almost all industrial plant and equipment areas.



Fans

- Air conditioning system
- Dryer
- Boiler fan
- Fans for controlling furnace temperature
- Roof fans controlled as a group
- Refrigerator
- Built-in blower in a film-manufacturing machine
- Fan for separator
- Cooling-tower fans
- Ventilating fans
- Air-conditioning equipment



Electric pumps

- Tankless water-supply system
- Submersible pump
- Vacuum pump
- Fountain pump
- Cooling water pump
- Circulating hot water pump
- Well pump
- Pump for agricultural water storage
- Constant-flow pump
- Sludge pump

Food processing machines



- Food mixer
- Food slicer
- Grain processing machine
- Tea manufacturing machine
- Rice milling machine



Conveyance machinery

- Crane (traveling, traversing, hoisting)
- Automated warehouse
- Conveyor (belt, chain, screw, roller)
- Lift
- Car parking system
- Elevator, escalator
- Automatic door
- Shutter
- Speed changer

Textile/paper making machinery



- Spinning machine
- Knitting machine
- Textile printing machine
- Industrial sewing machine
- Slitter



Packaging machinery



- Individual packing / inner packing
- Packing machine
- Outer packing machine



Chemical machinery/wood working machines

- Fluids mixing machine
- Centrifugal separator
- Coating machine
- Take-up roller
- Router machine
- Sanding machine
- Planing machine



Machine tools

- Boring machine
- Winding machine
- Press
- Turntable
- Work positioning unit
- PC board drilling machine

Other machinery



- Automated feed / medicine mixing machine
- Commercial-use washing machine
- Offset printing press
- Bookbinding machine
- Car washing machine
- Shredder
- Dishwasher
- Test equipment

Standard Specifications

Single-phase 200V series

Type	FVR□□□E11S-7JE	0.1	0.2	0.4	0.75	1.5	2.2	
Nominal applied motor *1)	kW	0.1	0.2	0.4	0.75	1.5	2.2	
Output ratings	Rated capacity *2)	kVA	0.30	0.57	1.1	1.9	4.1	
	Rated voltage *3)	V	3-phase 200V/50Hz 200, 220, 230V/60Hz					
	Rated current *4)	A	0.8 (0.7)	1.5 (1.4)	3.0 (2.5)	5.0 (4.0)	8.0 (7.0)	11 (10)
	Overload capability		150% of rated current for 1min. 200% of rated current for 0.5s					
	Rated frequency	Hz	50, 60Hz					
Input ratings	Phases, Voltage, Frequency		1-phase 200 to 240V		50/60Hz			
	Voltage / frequency variations		Voltage: +10 to -10% (Voltage unbalance *5): 2% or less Frequency: +5 to -5%					
	Momentary voltage dip capability *6)		When the input voltage is 165V or more, the inverter can be operated continuously. When the input voltage drops below 165V from rated voltage, the inverter can be operated for 15ms. The smooth recovery mode is selectable (by Auto-restart function).					
	Rated current *7)	(with DCR) A	1.2	2.0	3.5	6.5	11.8	17.7
		(without DCR)	2.3	3.9	6.4	11.4	19.8	28.5
	Required power supply capacity *9)	kVA	0.3	0.4	0.7	1.3	2.4	3.6
Control	Starting torque	200% (with Dynamic torque-vector control selected)						
Braking	Braking torque (Standard) *10)	100			70			
	Braking torque (Using options)	150						
	DC injection braking	Starting frequency: 0.0 to 60.0Hz Braking time: 0.0 to 30.0s Braking level: 0 to 100% of rated current						
Enclosure (IEC 60529)	IP 20							
Cooling method	Natural cooling				Fan cooling			
Standards	-UL/cUL -Low Voltage Directive -EMC Directive -TUV -IEC 61800-2 (Ratings, specifications for low voltage adjustable frequency a.c. power drive systems) -IEC 61800-3 (EMC product standard including specific test methods)							
Mass	kg	0.6	0.7	0.7	1.2	1.8	1.9	

Three-phase 400V series

Type	FVR□□□E11S-4JE	0.4	0.75	1.5	2.2	3.7	5.5	7.5	
Nominal applied motor *1)	kW	0.4	0.75	1.5	2.2	3.7	5.5	7.5	
Output ratings	Rated capacity *2)	kVA	1.1	1.9	2.8	4.1	6.8	9.9	13
	Rated voltage *3)	V	3-phase 380, 400, 415V/50Hz, 380, 400, 440, 460V/60Hz						
	Rated current *4)	A	1.5 (1.4)	2.5 (2.1)	3.7 (3.7)	5.5 (5.3)	9.0 (8.7)	13 (12)	18 (16)
	Overload capability		150% of rated current for 1min. 200% of rated current for 0.5s						
	Rated frequency	Hz	50, 60Hz						
Input ratings	Phases, Voltage, Frequency		3-phase 380 to 480V		50/60Hz				
	Voltage / frequency variations		Voltage: +10 to -15% (Voltage unbalance *5): 2% or less Frequency: +5 to -5%						
	Momentary voltage dip capability *6)		When the input voltage is 300V or more, the inverter can be operated continuously. When the input voltage drops below 300V from rated voltage, the inverter can be operated for 15ms. The smooth recovery mode is selectable (by Auto-restart function).						
	Rated current *7)	(with DCR) A	0.82	1.5	2.9	4.2	7.1	10.0	13.5
		(without DCR) *8)	1.8	3.5	6.2	9.2	14.9	21.5	27.9
	Required power supply capacity *9)	kVA	0.6	1.1	2.1	3.0	5.0	7.0	9.4
Control	Starting torque	200% (with Dynamic torque-vector control selected)							
Braking	Braking torque (Standard) *10)	70			40		20		
	Braking torque (Using options)	150							
	DC injection braking	Starting frequency: 0.0 to 60.0Hz Braking time: 0.0 to 30.0s Braking level: 0 to 100% of rated current							
Enclosure (IEC 60529)	IP 20								
Cooling method	Natural cooling			Fan cooling					
Standards	-UL/cUL -Low Voltage Directive -EMC Directive -TUV -IEC 61800-2 (Ratings, specifications for low voltage adjustable frequency a.c. power drive systems) -IEC 61800-3 (EMC product standard including specific test methods)								
Mass	kg	1.1	1.2	1.3	1.4	1.9	4.5	4.5	

NOTES:
 *1) Normal applied motor indicates standard FUJI 4P motor. *2) Inverter output capacity (kVA) at 440V in 400V series, 220V in 200V series. *3) Output voltage cannot exceed the power supply voltage. *4) Current derating may be required in case of low impedance loads such as high frequency motor. Use the inverter at the current () or below where carrier frequency setting is higher than 4kHz (F26: 4 to 15) or the amb. temp. is 40°C or higher. *5) Refer to the IEC 61800-3 (5.2.3). *6) Tested at standard load condition (85% load). *7) This value is under FUJI original calculation method. (Refer to the Technical Information.) *8) Calculated value when connected to power supply of 500kVA. *9) When optional power-factor correcting DC REACTOR (DCR) is used. *10) With a nominal applied motor, this value is average torque when the motor decelerates and stops from 60Hz. (It may change according to motor loss.)

Three-phase 200V series

Type	FVR□□□E11S-2JE	0.1	0.2	0.4	0.75	1.5	2.2	3.7	5.5	7.5	
Nominal applied motor *1)		0.1	0.2	0.4	0.75	1.5	2.2	3.7	5.5	7.5	
Rated capacity *2)	kVA	0.30	0.57	1.1	1.9	3.0	4.2	6.5	9.5	12.5	
Output ratings	Rated voltage *3)	3-phase 200V/50Hz 200, 220, 230V/60Hz									
	Rated current *4)	A	0.8 (0.7)	1.5 (1.4)	3.0 (2.5)	5.0 (4.0)	8.0 (7.0)	11 (10)	17 (16.5)	25 (23.5)	33 (31)
	Overload capability	150% of rated current for 1min. 200% of rated current for 0.5s									
	Rated frequency	Hz	50, 60Hz								
	Phases, Voltage, Frequency	3-phase 200 to 230V 50/60Hz									
Input ratings	Voltage / frequency variations	Voltage: +10 to -15% (Voltage unbalance *5): 2% or less) Frequency: +5 to -5%									
	Momentary voltage dip capability *6)	When the input voltage is 165V or more, the inverter can be operated continuously. When the input voltage drops below 165V from rated voltage, the inverter can be operated for 15ms. The smooth recovery mode is selectable (by Auto-restart function).									
	Rated current *7)	(with DCR)	0.59	0.94	1.6	3.1	5.7	8.3	14.0	19.7	26.9
		(without DCR)	1.1	1.8	3.4	6.4	11.1	16.1	25.5	40.8	52.6
	Required power supply capacity *8)	kVA	0.3	0.4	0.6	1.1	2.0	2.9	4.9	6.9	9.4
Control	Starting torque	200% (with Dynamic torque-vector control selected)									
Braking	Braking torque (Standard) *9)	100	70				40		20		
	Braking torque (Using options)	150									
	DC injection braking	Starting frequency: 0.0 to 60.0Hz Braking time: 0.0 to 30.0s Braking level: 0 to 100% of rated current									
Enclosure (IEC 60529)	IP 20										
Cooling method	Natural cooling					Fan cooling					
Standards	-UL/cUL -Low Voltage Directive -EMC Directive -TÜV -IEC 61800-2 (Ratings, specifications for low voltage adjustable frequency a.c. power drive systems) -IEC 61800-3 (EMC product standard including specific test methods)										
Mass	kg	0.6	0.6	0.7	0.8	1.3	1.3	2.0	4.5	4.5	

NOTES:

*1) Normal applied motor indicates standard FUJI 4P motor. *2) Inverter output capacity (kVA) at 220V in 200V series. *3) Output voltage cannot exceed the power supply voltage. *4) Current derating may be required in case of low impedance loads such as high frequency motor. Use the inverter at the current () or below where carrier frequency setting is higher than 4kHz (F26: 4 to 15) or the amb. temp. is 40°C or higher. *5) Refer to the IEC 61800-3 (5.2.3). *6) Tested at standard load condition (85% load). *7) This value is under FUJI original calculation method. (Refer to the Technical Information.) *8) When optional power-factor correcting DC REACTOR (DCR) is used. *9) With a nominal applied motor, this value is average torque when the motor decelerates and stops from 60Hz. (It may change according to motor loss.)





Common Specifications

Item		Explanation	
Output frequency	Setting	Maximum frequency	50 to 400Hz *1)
		Base frequency	25 to 400Hz
		Starting frequency	0.1 to 60.0Hz, Holding time: 0.0 to 10.0s
		Carrier frequency *2)	0.75 to 15kHz
	Accuracy (Stability)	<ul style="list-style-type: none"> Analog setting : ±0.2% of Maximum frequency (at 25±10°C) Digital setting : ±0.01% of Maximum frequency (at -10 to +50°C) 	
Setting resolution	<ul style="list-style-type: none"> Analog setting : 1/3000 of Maximum frequency ex.) 0.02Hz at 60Hz, 0.04Hz at 120Hz, 0.15Hz at 400Hz Digital setting : 0.01Hz at Maximum frequency of up to 99.99Hz (0.1Hz at Maximum frequency of 100.0Hz and above) LINK setting : ± 1/20000 of Maximum frequency ex.) 0.003Hz at 60Hz, 0.006Hz at 120Hz, 0.02Hz at 400Hz • 0.01Hz (Fixed) 		
Control	Control method	<ul style="list-style-type: none"> V/f control (Sinusoidal PWM control) • Dynamic torque-vector control (Sinusoidal PWM control) 	
	Voltage / freq. (V/f) characteristic	Adjustable at base and maximum frequency, with AVR control : 160 to 480V (400V series), 80 to 240V (200V series)	
	Torque boost	Selectable by load characteristics: Constant torque load (Auto/manual), Variable torque load (Manual)	
	Operation method	<ul style="list-style-type: none"> KEYPAD operation : key, key Digital input signal operation : FWD or REV command, Coast-to-stop command, etc. LINK operation : RS485 (Standard) Profibus-DP, Interbus-S, DeviceNet, Modbus Plus, CAN Open (Option) 	
	Frequency setting (Frequency command)	<ul style="list-style-type: none"> KEYPAD operation: or key External potentiometer (*) : 1 to 5kΩ Analog input : 0 to +10V DC (0 to +5V DC), 4 to 20mA DC (Reversible) 0 to ±10V DC (0 to ±5V DC)Reversible operation by polarized signal can be selected. (Inverse) +10 to 0V DC, 20 to 4mA DC.....Inverse mode operation can be selected. UP/DOWN control : Output frequency increases when UP signal is ON, and decreases when DOWN signal is ON. Multistep frequency : Up to 16 different frequencies can be selected by digital input signal. LINK operation : RS485 (Standard) Profibus-DP, Interbus-S, DeviceNet, Modbus Plus, CAN Open (Option) 	
	Running status signal	<ul style="list-style-type: none"> Transistor output (2 points) : RUN, FAR, FDT, OL, LU, TL, etc. Relay output (1 point) : Alarm output (for any fault) Analog (or pulse) output (1 point) : Output frequency, Output current, Output torque, etc. 	
	Acceleration / Deceleration time	0.01 to 3600s : • Independently adjustable acceleration and deceleration • 4 different times are selectable.	
	Frequency limiter	Mode select : Linear, S-curve (weak), S-curve (strong), Non-linear	
	Bias frequency	High and Low limiters can be preset.	
	Gain for frequency setting	Gain for frequency setting can be preset. (0.0 to 200.0%) ex.) Analog input 0 to +5V DC with 200% gain results in maximum frequency at 5V DC.	

NOTES: (*) Option

*1) For application at 120Hz or above, please contact FUJI.

*2) Inverter may automatically reduce carrier frequency, in accordance with ambient temperature or output current for protecting inverter.

	Item	Explanation
Control	Jump frequency control	Jump frequency (3 points) and its common jump hysteresis width (0 to 30Hz) can be preset.
	Rotating motor pick up (Flying start)	A rotating motor (including inverse rotating mode) can be smoothly picked up without stopping the motor (speed search method).
	Auto-restart after momentary power failure	Automatic restart is available without stopping motor after a momentary power failure (speed search method). When "Smooth recovery" mode is selected, the motor speed drop is held minimum. (The inverter searches the motor speed, and smoothly returns to setting frequency. Even if the motor circuit is temporarily opened, the inverter operates without a hitch.)
	Slip compensation	The inverter output frequency is controlled according to the load torque to keep motor speed constant. When the value is set at "0.00" and "Torque-vector" is set at "active", the compensation value automatically selects the Fuji standard motor. Slip compensation can be preset for the second motor.
	Droop operation	The motor speed droops in proportion to load torque (-9.9 to 0.0Hz).
	Torque limiter	<ul style="list-style-type: none"> When the motor torque reaches a preset limiting level, this function automatically adjusts the output frequency to prevent the inverter from tripping due to an overcurrent. Torque limiter 1 and 2 can be individually set, and are selectable with a digital input signal.
	PID control	<p>This function can control flowrate, pressure, etc. (with an analog feedback signal.)</p> <p>Reference signal</p> <ul style="list-style-type: none"> KEYPAD operation ( or  key) : 0.0 to 100.0% Voltage input (Terminal 12) : 0 to +10V DC Current input (Terminal C1) : 4 to 20mA DC Multistep frequency setting : Setting freq. / Max. freq. X 100 (%) RS485 : Setting freq. / Max. freq. X 100 (%) <p>Feedback signal</p> <ul style="list-style-type: none"> Terminal 12 (0 to +10V DC or +10 to 0V DC) Terminal C1 (4 to 20mA DC or 20 to 4mA DC)
	Automatic deceleration	<p>Torque limiter 1 (Braking) is set at "F41: 0" (Same as Torque limiter 2 (Braking)).</p> <ul style="list-style-type: none"> In deceleration : The deceleration time is automatically extended up to 3 times the setting time for tripless operation even if braking resistor not used. In constant speed operation : Based on regenerative energy, the frequency is increased and tripless operation is active.
	Second motor's setting	<p>This function is used for two motors switching operation.</p> <ul style="list-style-type: none"> The second motor's V/f characteristics (base and maximum frequency) can be preset. The second motor's circuit parameter can be preset. Torque-vector control can be applied to both motors.
	Energy saving operation	This function minimizes inverter and motor losses at light load.
Fan stop operation	This function is used for silent operation or extending the fan's lifetime.	
Indication (LED monitor)	Operation mode (Running)	<ul style="list-style-type: none"> Output frequency (Hz) Setting frequency (Hz) Output current (A) Output voltage (V) Motor synchronous speed (r/min) <ul style="list-style-type: none"> Constant rate of feeding time Line speed (m/min) PID reference value PID reference value (remote) PID feedback value
	Stopping	Selected setting value or output value
	Trip mode	<p>Displays the cause of trip by codes as follows.</p> <ul style="list-style-type: none"> OC1 (Overcurrent during acceleration) OC2 (Overcurrent during deceleration) OC3 (Overcurrent during running at constant speed) Lin (Input phase loss) OU1 (Overvoltage during acceleration) OU2 (Overvoltage during deceleration) OU3 (Overvoltage during running at constant speed) LU (Undervoltage) OH1 (Overheating at heat sink) OH2 (External thermal relay tripped) <ul style="list-style-type: none"> dBH (Overheating at DB circuit) OL1 (Motor 1 overload) OL2 (Motor 2 overload) OLU (Inverter unit overload) Er1 (Memory error) Er2 (KEYPAD panel communication error) Er3 (CPU error) Er4 (Option error) Er5 (Option error) Er7 (Output phase loss error, impedance imbalance) Er8 (RS485 error)
	Running or trip mode	<ul style="list-style-type: none"> Trip history: Cause of trip by code (Even when main power supply is off, trip history data of the last 4 trips are retained.)
	Charge lamp	When the DC link circuit voltage is higher than 50V, the charge lamp is ON.
Protection	Overload	Protects the inverter by electronic thermal and detection of inverter temperature.
	Overvoltage	Detects DC link circuit overvoltage, and stops the inverter. (400V series: 800V DC, 200V series: 400V DC)
	Incoming surge	Protects the inverter against surge voltage between the main circuit power line and the ground.
	Undervoltage	Detects DC link circuit undervoltage, and stops the inverter. (400V series: 400V DC, 200V series: 200V DC)
	Input phase loss	Phase loss protection for power line input.
	Overheating	Protects the inverter by detection of inverter temperature.
	Short-circuit	Short-circuit protection for inverter output circuit
	Ground fault	Ground fault protection for inverter output circuit
	Motor overload	<ul style="list-style-type: none"> Electronic thermal overload relay can be selected for standard motor or inverter motor Thermal time constant (0.5 to 10.0 minutes) can be preset for a special motor. The second motor's electronic thermal overload relay can be preset for 2-motor changeover operation. Outputs a warning signal at preset level before inverter trip.
	* (overload early warning)	
	DB resistor overheating	<ul style="list-style-type: none"> Prevents DB resistor overheating by internal electronic thermal overload relay. (The inverter stops electricity discharge operation to protect the DB resistor.)
	Stall prevention	<ul style="list-style-type: none"> Controls the output frequency to prevent  (overcurrent) trip when the output current exceeds the limit value during acceleration. Lowers the output frequency to hold almost constant torque when the output current exceeds the limit value during operation at constant speed. Controls the output frequency to prevent  (overvoltage) trip when the DC link circuit voltage exceeds the limit value during deceleration.
	Output phase loss	When the inverter executes tuning, detects each phase impedance imbalance.
	Motor protection by PTC thermistor	When the motor temperature exceeds allowable value, the inverter trips automatically.
Auto reset	When the inverter is tripped, it resets automatically and restarts.	
Condition (Installation and operation)	Installation location	Free from corrosive gases, flammable gases, oil mist, dusts, and direct sunlight. Indoor use only. Pollution degree 2 for Low Voltage Directive.
	Altitude	1000m or less. Applicable to 3000m with power derating (-10%/1000m)
	Ambient temperature	-10 to +50 °C
	Ambient humidity	5 to 95%RH (non-condensing)
Storage condition	Vibration	3mm at from 2 to less than 9Hz, 9.8m/s ² at from 9 to less than 20Hz 2m/s ² at from 20 to less than 55Hz, 1m/s ² at from 55 to less than 200Hz
		<ul style="list-style-type: none"> Temperature : -25 to +65 °C Humidity : 5 to 95%RH (non-condensing)

Keypad panel Operation

The following diagram is for reference only. For detailed wiring diagrams, refer to the relevant instruction manual.

Power supply 1-phase
200 to 240V
50/60Hz
* MCCB or ELCB

Power supply 3-phase
400 to 480V
50/60Hz
or
200 to 230V
50/60Hz
* MCCB or ELCB

Analog input
POT power supply
Voltage input
Current input

Digital input
PLC
FWD
REV
X1
X2
X3
X4
X5
CM
FM

Motor
U
V
W
G (*5)

Control
P1
P (+) (*1)
DB
N (-)

Output
30C
30B
30A
P24
Y2
Y1
CME

Alarm output (for any fault)

Transistor output

Analog/pulse output
FM

Notes:

- Run/Stop Press **RUN** or **STOP** key on the keypad panel.
- Setting frequency Press **▲** or **▼** key on the keypad panel.

NOTES:

- When connecting an optional DC REACTOR, remove the jumper wire that connects the terminals [P1] and [P+].
- Keep the control circuit wires at least 100mm away from the main circuit wires and put them in separate ducts to prevent noise and resultant malfunctions. When control wiring crosses the main wiring, ensure that they cross each other at right angles.
- For the wiring of the control circuit, use shielded or twisted wires with the shortest possible length. (When using shielded wires, connect one end of the shields to the inverter ground terminal and leave the other end free.)
- If there is a magnetic contactor or a solenoid close to the inverter, connect a surge suppresser to the coil in parallel connection. Keep the wiring length to a minimum.
- Terminal for grounding the motor. Connect it, if necessary.

External signal input Operation

The following diagram is for reference only. For detailed wiring diagrams, refer to the relevant instruction manual.

Power supply 1-phase
200 to 240V
50/60Hz
* MCCB or ELCB

Power supply 3-phase
400 to 480V
50/60Hz
or
200 to 230V
50/60Hz
* MCCB or ELCB

Analog input
Voltage input (0 to +10V DC)
Current input (4 to 20mA DC)

Digital input
Forward command
Reverse command
X1
X2
X3
X4
X5
CM
FM

Motor
U
V
W
G (*5)

Control
P1
P (+) (*1)
DB
N (-)

Output
30C
30B
30A
P24
Y2
Y1
CME

Alarm output (for any fault)

Transistor output

Analog/pulse output
FM

External braking resistor (DB)
P
DB
N (-)
P (+)
Y2
Y1
CME

Notes:

- Run/Stop operation and frequency setting through external signals
When "1" is set at **FO1**, you can set a frequency by using an input signal for 0 to 10V DC. When "2" is set at **FO1**, you can set a frequency by using an input signal for 4 to 20mA DC. In both cases, set "1" at **FO2**.

NOTES:

- When connecting an optional DC REACTOR, remove the jumper wire that connects the terminals [P1] and [P+].
- If there is a magnetic contactor or a solenoid close to the inverter, connect a surge suppresser to the coil in parallel connection. Keep the wiring length to a minimum.
- For the wiring of the control circuit, use shielded or twisted wires with the shortest possible length. When using shielded wires, connect the shields to the inverter ground terminal.
- (THR) terminal function can be used by assigning code "8" (External fault) to any of X1 to X5 terminal (function code E01 to E05).
- Terminal for grounding the motor. Connect it, if necessary.

Terminal Functions

Terminal Functions

	Symbol	Terminal name	Function	Remarks	Func. code
Main circuit	L1/R, L2/S, L3/T	Power input	Connect a 3-phase power supply.		
	L1/L, L2/N	Power input	Connect a 1-phase power supply.		
	U, V, W	Inverter output	Connect a 3-phase induction motor.		
	P1, P(+)	For DC REACTOR	Connect the DC REACTOR for power-factor correcting or harmonic current reducing.	DC REACTOR: Option	
	P(+), N(-)	For DC link circuit	Used for DC bus connection system.		
	P(+), DB	For EXTERNAL BRAKING RESISTOR	Connect the EXTERNAL BRAKING RESISTOR (Option)		
	⊕ G	Grounding	Ground terminal for inverter chassis (housing).		
Analog input	13	Potentiometer power supply	+10V DC power supply for frequency setting POT (POT: 1 to 5kΩ)	• Allowable maximum output current : 10mA	
	12	Voltage input	• 0 to +10V DC/0 to 100% (0 to +5V DC/0 to 100%) • Reversible operation can be selected by function setting. 0 to ±10V DC /0 to ±100% (0 to ±5V DC/0 to ±100%)	• Input impedance: 22kΩ • Allowable maximum input voltage: ±15V DC • If input voltage is 10 to 15V DC, the inverter estimates it to 10V DC.	F01, C30
			(PID control)	Used for PID control reference signal or feedback signal.	F01, H21
	C1	Current input	• 4 to 20mA DC/0 to 100%	• Input impedance: 250Ω	F01
			(PID control)	Used for PID control reference signal or feedback signal.	F01, H21
			(PTC thermistor input)	The PTC thermistor (for motor protection) can be connected to terminal C1 - 11.	H26, H27
11	Common	Common for analog signal	Isolated from terminal CME and CM.		
Digital input	FWD	Forward operation command	FWD: ON The motor runs in the forward direction. FWD: OFF The motor decelerates and stops.	When FWD and REV are simultaneously ON, the motor decelerates and stops.	F02
	REV	Reverse operation command	REV: ON The motor runs in the reverse direction. REV: OFF The motor decelerates and stops.		
	X1	Digital input 1	These terminals can be preset as follows.	• ON state maximum input voltage: 2V (maximum source current : 5mA) • OFF state maximum terminal voltage: 27V (allowable maximum leakage current: 0.5mA)	E01 to E05
	X2	Digital input 2			
	X3	Digital input 3			
	X4	Digital input 4			
	X5	Digital input 5			
	(SS1) (SS2) (SS4) (SS8)	Multistep freq. selection	(SS1) : 2 (0, 1) different frequencies are selectable. (SS1,SS2) : 4 (0 to 3) different frequencies are selectable. (SS1,SS2,SS4) : 8 (0 to 7) different frequencies are selectable. (SS1,SS2,SS4,SS8) : 16 (0 to 15) different frequencies are selectable.	Frequency 0 is set by F01 (or C30). (All signals of SS1 to SS8 are OFF)	C05 to C19
	(RT1)	ACC / DEC time selection	(RT1) : 2 (0, 1) different ACC / DEC times are selectable.	Time 0 is set by F07/F08.	F07, F08 E10, E11
	(HLD)	3-wire operation stop command	Used for 3-wire operation. (HLD): ON The inverter self-holds FWD or REV signal. (HLD): OFF The inverter releases self-holding.		
	(BX)	Coast-to-stop command	(BX): ON Motor will coast-to-stop. (No alarm signal will be output.)	• The motor restarts from 0Hz by turning off BX with the operation command (FWD or REV) ON. • Assigned to terminal X4 at factory setting.	H11
	(RST)	Alarm reset	(RST): ON Faults are reset. (This signal should be held for more than 0.1s.)	• During normal operating, this signal is ignored. • Assigned to X5 at factory setting.	
	(THR)	Trip command (External fault)	(THR): OFF "OH2 trip" occurs and motor will coast-to-stop.	This alarm signal is held internally.	
	(Hz2/Hz1)	Freq. set 2 / Freq. set 1	(Hz2/Hz1): ON Freq. set 2 is effective.	If this signal is changed while the inverter is running, the signal is effective only after the inverter stops.	F01 / C30
	(M2/M1)	Motor 2 / Motor 1	(M2/M1): ON The motor circuit parameter and V/f characteristics are changed to the second motor's ones.	If this signal is changed while the inverter is running, the signal is effective only after the inverter stops.	P01 to P10 / A10 to A19
	(DCBRK)	DC brake command	(DCBRK): ON The DC injection brake is effective. (In the inverter deceleration mode)	If the operation command(FWD/REV) is input while DC braking is effective, the operation command (FWD/REV) has priority.	F20 to F22
	(TL2/TL1)	Torque limiter 2 / Torque limiter 1	(TL2/TL1): ON Torque limiter 2 is effective.		F40, F41 / E16, E17
	(UP)	UP command	(UP): ON The output frequency increases.	When UP and DOWN commands are simultaneously ON, DOWN signal is effective.	F01, C30
	(DOWN)	DOWN command	(DOWN): ON The output frequency decreases. • The output frequency change rate is determined by ACC / DEC time. • Restarting frequency can be selected from 0Hz or setting value at the time of stop.		
	(WE-KP)	Write enable for KEYPAD	(WE-KP): ON The data is changed by KEYPAD.		
	(Hz/PID)	PID control cancel	(Hz/PID): ON The PID control is canceled, and frequency setting by KEYPAD () or () is effective.		H20 to H25
	(IVS)	Inverse mode changeover	(IVS): ON Inverse mode is effective in analog signal input.	If this signal is changed while the inverter is running, the signal is effective only after the inverter stops.	F01, C30
	(LE)	Link enable (RS485, Bus)	(LE): ON The link operation is effective. Used to switch operation between ordinary operation and link operation to communication.	RS485: Standard, Bus: Option	H30
PLC	PLC terminal	Connect PLC power supply to avoid malfunction of the inverter that has SINK type digital input, when PLC power supply is off.			
CM	Common	Common for digital signal	Isolated from CME and 11.		

Terminal Functions

	Symbol	Terminal name	Function	Remarks	Func. code
Analog output	FM (11)	Analog monitor (Common)	Output voltage (0 to 10V DC) is proportional to selected function's value as follows. The proportional coefficient and bias value can be preset. <ul style="list-style-type: none"> • Output frequency 1 (Before slip compensation) (0 to max. frequency) • Output frequency 2 (After slip compensation) (0 to max. frequency) • Output current (0 to 200%) • Output voltage (0 to 200%) • Output torque (0 to 200%) • Load factor (0 to 200%) • Input power (0 to 200%) • PID feedback value (0 to 100%) • DC link circuit voltage (0 to 1000V) 	Allowable maximum output current: 2mA	F30, F31
Pulse output	FM (11)	Pulse rate monitor (Common)	<ul style="list-style-type: none"> * Pulse rate mode : Pulse rate is proportional to selected function's value* (50% duty pulse) * Average voltage mode : Average voltage is proportional to selected function's value* (2670p/s pulse width control) * Kinds of function to be output is same as those of analog output (FM). 	Allowable maximum output current : 2mA	F33 to F35
Transistor output	P24	DC voltage supply	Power supply for transistor output load. (+24V DC, 50mA max.)		
	Y1 Y2	Transistor output 1 Transistor output 2	Output the selected signals from the following items.	<ul style="list-style-type: none"> • ON state maximum output voltage : 2V (Allowable maximum sink current : 50mA) • OFF state maximum leakage current : 0.1mA (Allowable maximum voltage : 27V) 	E20, E21
	(RUN)	Inverter running	Outputs ON signal when the output frequency is higher than starting frequency.		
	(FAR)	Frequency equivalence signal	Outputs ON signal when the difference between output frequency and setting frequency is smaller than FAR hysteresis width.		E30
	(FDT)	Frequency level detection	Outputs ON signal by comparison of output frequency and preset value (level and hysteresis).		E31, E32
	(LU)	Undervoltage detection signal	Outputs ON signal when the inverter stops by undervoltage while the operation command is ON.		
	(B/D)	Torque polarity	Outputs ON signal in braking or stopping mode, and OFF signal in driving mode.		
	(TL)	Torque limiting	Outputs ON signal when the inverter is in torque-limiting mode.		
	(IPF)	Auto-restarting	Outputs ON signal during auto restart operation (Instantaneous power failure) mode. (including "restart time")		
(OL)	Overload early warning	<ul style="list-style-type: none"> • Outputs ON signal when the electronic thermal value is higher than preset alarm level. • Outputs ON signal when the output current value is higher than preset alarm level. 		E33 to E35	
	CME	Common (transistor output)	Common for transistor output signal.	Isolated from terminals CM and 11.	
Relay output	30A, 30B 30C	Alarm relay output	Outputs a contact signal when a protective function is activated. Changeable exciting mode active or non-exciting mode active by function "F36".	<ul style="list-style-type: none"> • Contact rating : 250V AC, 0.3A, $\cos\phi=0.3$ 48V DC, 0.5A, non-inductive (for LVD) 42V DC, 0.5A, non-inductive (for UL/cUL) 	F36
LINK		RS485 I/O terminal	Connect the RS485 link signal.		

Terminal Arrangement

Main circuit terminals

Control circuit terminals

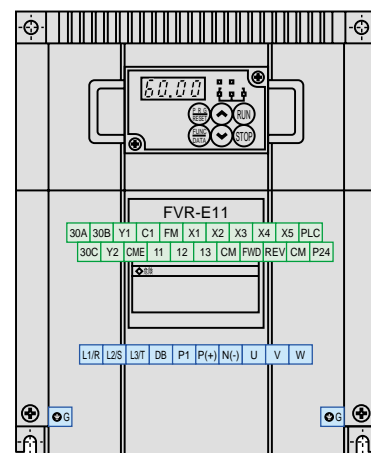
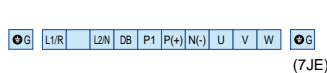
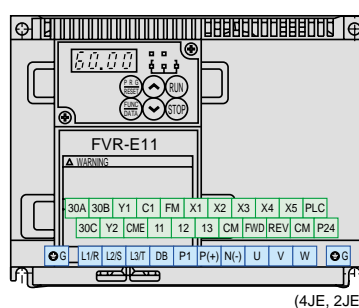
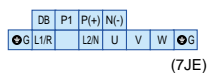
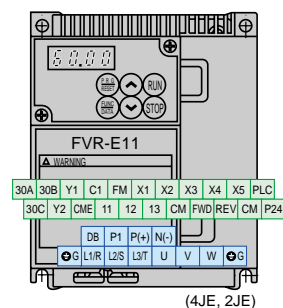
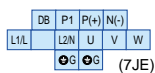
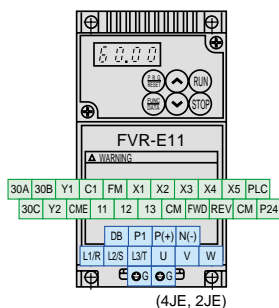

FVR0.1, 0.2, 0.4E11S-7JE
FVR0.1 to 0.75E11S-2JE

FVR0.75E11S-7JE
FVR0.4 to 2.2E11S-4JE
FVR1.5, 2.2E11S-2JE

FVR1.5, 2.2E11S-7JE
FVR3.7E11S-4JE
FVR3.7E11S-2JE

FVR5.5, 7.5E11S-4JE
FVR5.5, 7.5E11S-2JE

Keypad Panel Functions and Operations

Keypad panel

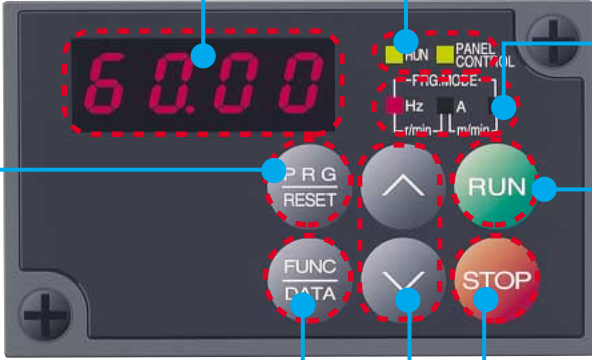

LED monitor
In Operation mode:
 Displays the setting frequency, output current, voltage, motor speed, or line speed.
In Trip mode:
 Displays code indicating the cause of trip.

Operation mode indication
 RUN :
 This LED goes on during operating.
 PANEL CONTROL :
 When Function code **F 0 2** is set at **0 0 0**, **0 0 2**, or **0 0 3** (Keypad operation), this LED goes on.

Unit indication
 Displays the unit of the value shown on the LED monitor.

Program/Reset key
 Switches between operation mode and program mode.
When tripped:
 Releases the trip-stop state and changes to operation mode.





Run key
 Starts the inverter.
In Stop mode:
 Invalid when the function code **F 0 2** is set at **0 0 1** (external operation).

Function/Data select key
 Changes the displayed values of LED monitor, selects and stores the function codes and data codes.

Stop key
 Stops the inverter.
In Operation mode:
 Invalid when the function code **F 0 2** is set at **0 0 1** (external operation).





Up/Down keys
In Operation mode:
 Increases or decreases the frequency or motor speed.
In Program mode:
 Increases or decreases function code number and data set value.



Keypad panel operation

1. Turn on the power supply, press the  or  key to set the output frequency. When you press the  key, the motor will run at the set frequency and with function code/data at factory shipment. When you press the  key, the motor will decelerates and stops.

2. Procedure for selecting and changing function codes and data codes.

The keypad panel operation how to select a function code and change its data code is explained below.

- ① Press the  key to select the program mode.
- ② Pressing  key alternates the displayed data between the function code and its data.
 (**F 0 0** ▶ **0 0 0** ▶ **F 0 1** ▶ **0 0 0** ▶)
- ③ With data displayed, press the  or  key to change the data code.
- ④ Press the  key to update the data for the selected function code.

* In step ② above, if the  or  key is pressed when the function code is displayed, only the function code changes sequentially (see below).

(**F 0 0** ▶ **F 0 1** ▶ **F 0 2** ▶ **F 0 3** ▶)



The keypad panel modes are classified in the following 5 modes.

Monitor, keys	Mode	Program mode (operation stopped)	Program mode (during operation)	Stop mode	Operation mode	Trip mode	
Monitor		Displays the function code or data code. (Blinking)	Displays the function code or data code. (Lighting)	Displays the set frequency, output current, output voltage, motor speed, line speed. (Blinking)	Displays the output frequency, output current, output voltage, motor speed, line speed. (Lighting)	Displays the trip content or alarm history. (Blinking or lighting)	
		Indicates the PRG mode during stopping.	Indicates the PRG mode during operation.	Unit indication of the above value.	Unit indication of the above value.	None	
							Not lit
		<input type="checkbox"/> PANEL CONTROL	Indicates whether keypad panel operation or external signal operation. (ON during keypad panel operation)				None (Lighting)
		<input type="checkbox"/> RUN	Indicates the operation has stopped. (<input type="checkbox"/> RUN not lit)	Indicates during operation. (<input checked="" type="checkbox"/> RUN lighting)	Indicates the operation has stopped. (<input type="checkbox"/> RUN not lit)	Indicates during operation. (<input checked="" type="checkbox"/> RUN lighting)	Indicates "stopping in trip mode." (<input checked="" type="checkbox"/> RUN lighting)
Keys		Switches to the stop mode.	Changes to operation mode.	Switches to "Program mode (operation stopped)."	Switches to "Program mode during operation."	Releases the trip and switches to "stop mode" or "operation mode."	
		Changes the display between function code and data code, stores data code, and then updates function codes.		Shifts the value on the LED monitor and the unit of the unit indication LED.		Invalid	
		Increases/decreases function code number and data code.		Increases/decreases the setting of frequency, motor speed, line speed.		Displays the alarm history.	
		Invalid	Invalid	Switches to operation mode.	Invalid	Invalid	
		Invalid	Switches to "stop mode" or "Program mode (operation stopped)."	Invalid	Switches to the stop mode.	Invalid	

* Procedure for selecting function codes and data codes (Ex. Changing data code from to of function code)

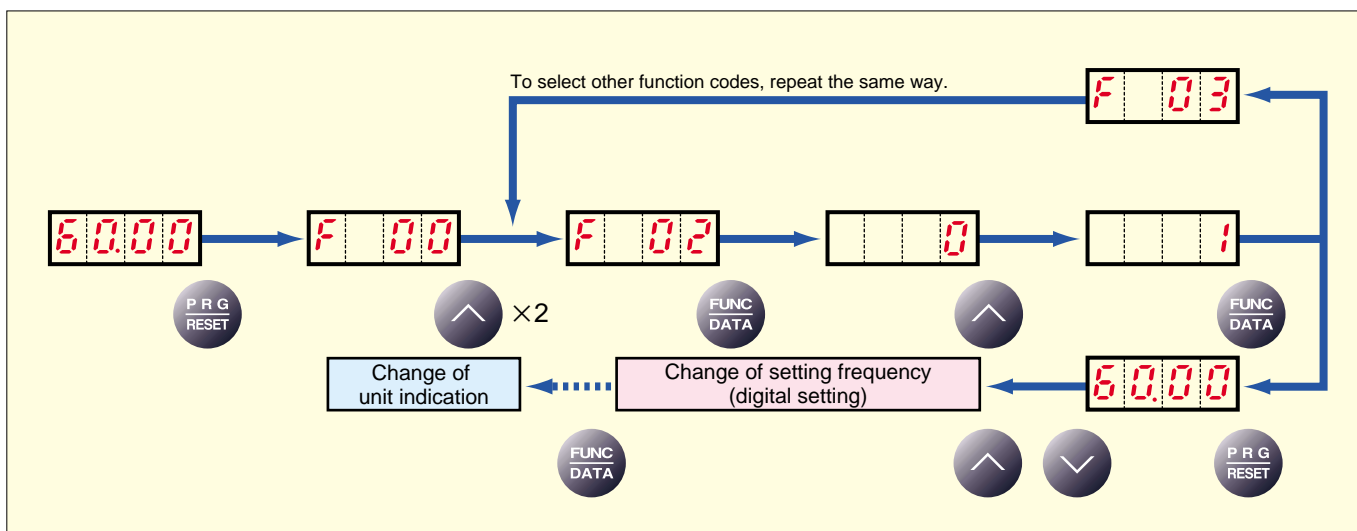

The functions in the yellow boxes can be set while the inverter is running. Other functions must be set while the inverter is stopped.

Extension Terminal Functions

	Function Code	Name	Setting range	Min. unit	Factory setting		
X1-X5 Terminal	E01	X1 terminal function	Selects from the following items. 0 : Multistep freq. selection (16 steps) 1 : : 2 : : 3 : : 4 : ACC / DEC time selection (1 step) 5 : 3-wire operation stop command 6 : Coast-to-stop command 7 : Alarm reset 8 : Trip command (External fault) 9 : Freq. set. 2 / Freq. set. 1	-	0		
	E02	X2 terminal function		[SS1] 10 : Motor 2 / Motor 1	-	1	
	E03	X3 terminal function		[SS2] 11 : DC brake command	[M2/M1]	-	2
	E04	X4 terminal function		[SS4] 12 : Torque limiter 2 / Torque limiter 1	[TL2/TL1]	-	6
	E05	X5 terminal function		[SS8] 13 : UP command	[UP]	-	7
				[RT1] 14 : DOWN command	[DOWN]	-	
				[HLD] 15 : Write enable for KEYPAD	[WE-KP]		
				[BX] 16 : PID control cancel	[Hz/PID]		
				[RST] 17 : Inverse mode changeover (terminals 12 and C1)	[IVS]		
				[THR] 18 : Link enable (Bus,RS485)	[LE]		
ACC 2	E10	Acceleration time 2	0.01 to 3600s	0.01s	10.0		
DEC 2	E11	Deceleration time 2		0.01s	10.0		
	E16	Torque limiter 2 (Driving)	20 to 200%, 999% (999: No limit) *2)	1%	999		
	E17	(Braking)	0 (Automatic deceleration control), 20 to 200%, 999% (999: No limit) *2)	1%	999		
Y1, Y2 Terminal	E20	Y1 terminal function	Selects from the following items. 0 : Inverter running 1 : Frequency equivalence signal 2 : Frequency level detection 3 : Undervoltage detection signal 4 : Torque polarity detection (Braking/Driving)	-	0		
	E21	Y2 terminal function		[RUN] 5 : Torque limiting	[TL]	-	7
				[FAR] 6 : Auto-restarting	[IPF]		
				[FDT] 7 : Overload early warning	[OL]		
				[LU] 8 : Lifetime alarm (main circuit capacitor)	[LIFE]		
		[B/D] 9 : 2nd Freq. equivalence detection	[FAR2]				
	E29	Frequency equivalence delay	0.01 to 10.0s	0.01s	0.1		
	E30	FAR function signal (Hysteresis)	0.0 to 10.0 Hz	0.1Hz	2.5		
	E31	FDT function signal (Level)	0 to 400 Hz	1Hz	60		
	E32	(Hysteresis)	0.0 to 30.0 Hz	0.1Hz	1.0		
	E33	OL function signal (Mode select)	0 : Thermal calculation 1 : Output current	-	0		
	E34	(Level) (Timer)	Approx. 20 to 200% of rated current 0.0 to 60.0s	0.01A 0.1s	*1 10.0		
LED Monitor	E39	Display coefficient for constant rate of feeding time	0.00 to 9.999	0.001			
	E40	Display coefficient A / Feeding amount (for constant rate of feeding time)	0.00 to 200.0 0.00 to 200.0m	0.01 0.01m	0.01		
	E41	Display coefficient B	0.00 to 200.0	0.01	0.00		
	E42	LED Display filter	0.0 to 5.0s	0.1s	0.5		

The functions in the yellow boxes can be set while the inverter is running. Other functions must be set while the inverter is stopped.

Control Functions of Frequency

	Function Code	Name	Setting range	Min. unit	Factory setting
Jump Hz Control	E01	Jump frequency (Jump freq. 1)	0 to 400Hz	1Hz	0
	E02	(Jump freq. 2)		1Hz	0
	E03	(Jump freq. 3)		1Hz	0
	E04	(Hysteresis)		1Hz	3
Multi-Hz Control	E05	Multistep frequency setting (Freq. 1)	0.00 to 400.0Hz	0.01Hz	0.00
	E06	(Freq. 2)		0.01Hz	0.00
	E07	(Freq. 3)		0.01Hz	0.00
	E08	(Freq. 4)		0.01Hz	0.00
	E09	(Freq. 5)		0.01Hz	0.00
	E10	(Freq. 6)		0.01Hz	0.00
	E11	(Freq. 7)		0.01Hz	0.00
	E12	(Freq. 8)		0.01Hz	0.00
	E13	(Freq. 9)		0.01Hz	0.00
	E14	(Freq. 10)		0.01Hz	0.00
	E15	(Freq. 11)		0.01Hz	0.00
	E16	(Freq. 12)		0.01Hz	0.00
	E17	(Freq. 13)		0.01Hz	0.00
	E18	(Freq. 14)		0.01Hz	0.00
	E19	(Freq. 15)		0.01Hz	0.00
Timer Operation	E21	Timer operation	0 : Inactive 1 : Active	-	0
	E22	(Stage 1)	• Operation time: 0.00 to 3600s	0.01s	0.00
	E30	Frequency command 2	0 : KEYPAD operation (or key) to 8 : UP/DOWN control 2 (initial freq. = last value)	-	2
	E31	Offset (Terminal 12)	-5.0 to +5.0%	0.1%	0.0
	E32	(Terminal C1)	-5.0 to +5.0%	0.1%	0.0
	E33	Analog setting signal filter	0.00 to +5.00s	0.01s	0.05

The functions in the yellow boxes can be set while the inverter is running. Other functions must be set while the inverter is stopped.

Motor Parameters

	Function Code	Name	Setting range	Min. unit	Factory setting
Motor 1	P01	Number of motor 1 poles	2 to 14	2	4
	P02	Motor 1 (Capacity)	3.7kW or smaller : 0.01 to 5.50 kW 5.5kW or larger : 0.01 to 11.00 kW	0.01kW	*1)
	P03	(Rated current)	0.00 to 99.9 A	0.01A	*1)
	P04	(Tuning)	0 : Inactive 1 : Active (One time tuning of %R1 and %X (on motor stopping mode)) 2 : Active (One time tuning of %R1, %X and lo (on motor running mode))	-	0
	P05	(On-line Tuning)	0 : Inactive 1 : Active (Real time tuning of %R2)	-	0
	P06	(No-load current)	0.00 to 99.9 A	0.01A	*1)
	P07	(%R1 setting)	0.00 to 50.00 %	0.01%	*1)
	P08	(%X setting)	0.00 to 50.00 %	0.01%	*1)
	P09	(Slip compensation control 1)	0.00 to +15.00Hz	0.01Hz	0.00
	P10	(Slip compensation response time)	0.01 to 10.00s	0.01s	0.5

Function settings

The functions in the yellow boxes can be set while the inverter is running. Other functions must be set while the inverter is stopped.

High Performance Functions

	Function Code	Name	Setting range	Min. unit	Factory setting
High Performance Functions	H01	Accumulated operation time	Monitoring only	1h	0
	H02	Trip history	Monitoring only	-	-
	H03	Data initializing (Data reset)	0 : Manual set value 1 : Return to factory set value	-	0
	H04	Auto-reset (Times)	0 (Inactive), 1 to 10 times	1	0
	H05	(Reset interval)	2 to 20s	1s	5
	H06	Fan stop operation	0 : Inactive 1 : Active (Fan stops at low temperature mode) for 1.5kW or larger model only	-	0
	H07	ACC/DEC pattern (Mode select)	0 : Linear 2 : S-curve (strong) 1 : S-curve (weak) 3 : Non-linear (For variable torque load)	-	0
	H09	Start mode (Rotating motor pick up)	0 : Inactive 1 : Active (Only when Auto-restart after momentary power failure mode) 2 : Active (All start modes)	-	1
	H10	Energy-saving operation	0 : Inactive 1 : Active (Only when torque boost "F09" is set at manual setting mode.)	-	0
	H11	DEC mode	0 : Normal (according to "H07" mode) 1 : Coast-to-stop	-	0
	H12	Instantaneous overcurrent limiting	0 : Inactive 1 : Active	-	1
	H13	Auto-restart (Restart time)	0.1 to 5.0s	0.1s	0.5
	H14	(Freq. fall rate)	0.00 to 100.00Hz/s	0.01Hz/s	10.00
	PID Control	H20	PID control (Mode select)	0 : Inactive 1 : Active (PID output 0 to 100% / Frequency 0 to max.) 2 : Active (Inverse operation mode : PID output 0 to 100% / Frequency max. to 0)	-
H21		(Feedback signal)	0 : Terminal 12 (0 to +10V) 2 : Terminal 12 (+10 to 0V) 1 : Terminal C1 (4 to 20mA) 3 : Terminal C1 (20 to 4mA)	-	1
H22		(P-gain)	0.01 to 10.00	0.01	0.10
H23		(I-gain)	0.0 : Inactive 0.1 to 3600s	0.1s	0.0
H24		(D-gain)	0.00 : Inactive 0.01 to 10.0s	0.01s	0.00
H25	(Feedback filter)	0.0 to 60.0s	0.1s	0.5	
Y1, Y2 Terminal	H26	PTC thermistor (Mode select)	0 : Inactive 1 : Active	-	0
	H27	(Level)	0.00 to 5.00V	0.01V	1.60
	H28	Droop operation	-9.9 to 0.0Hz	0.1Hz	0.0
Serial Link	H30	Serial link (Function select)	(Code) (Monitor) (Frequency command) (Operation command) 0 : X - - X : Valid 1 : X X - - - : Invalid 2 : X - X 3 : X X X	-	0
	H31	RS 485 (Address)	1 to 31	1	1
	H32	(Mode select on no response error)	0 : Trip and alarm (Er8) 1 : Operation for H33 timer, and alarm (Er8) 2 : Operation for H33 timer, and retry to communicate. * If the retry fails, then the inverter trips ("Er 8"). 3 : Continuous operation	-	0
	H33	(Timer)	0 to 60.0s	0.1s	2.0
	H34	(Baud rate)	0 : 19200 bit/s 2 : 4800 1 : 9600 3 : 2400 4 : 1200	-	1
	H35	(Data length)	0 : 8 bit 1 : 7 bit	-	0
	H36	(Parity check)	0 : No checking 1 : Even parity 2 : Odd parity	-	0
	H37	(Stop bits)	0 : 1 bit 1 : 2 bit	-	0
	H38	(No response error detection time)	0 (No detection), 1 to 60s	1s	0
	H39	(Response interval)	0.00 to 1.00s	0.01s	0.01
Diagnostic	H40	Maximum temperature of heat sink	Monitoring only	°C	-
	H41	Maximum effective current	Monitoring only	A	-
	H42	Main circuit capacitor lifetime	Monitoring only	%	-
	H43	Cooling fan accumulated operation time	Monitoring only	10h	-
	H44	Inverter ROM version	Monitoring only	-	-
	H45	Keypad panel ROM version	Monitoring only	-	-
	H46	Option ROM version	Monitoring only	-	-

The functions in the yellow boxes can be set while the inverter is running. Other functions must be set while the inverter is stopped.

Alternative Motor Parameters

	Function Code	Name	Setting range	Min. unit	Factory setting
Motor 2	R01	Maximum frequency 2	50 to 400Hz	1Hz	60
	R02	Base frequency 2	25 to 400Hz	1Hz	60
	R03	Rated voltage 2 (at Base frequency 2)	0 (Free), 320 to 480V (400V class) 0 (Free), 80 to 240V (200V class)	1V	380 220
	R04	Maximum voltage 2 (at Maximum frequency 2)	320 to 480V (400V class) 80 to 240V (200V class)	1V	400 200
	R05	Torque boost 2	0 : Automatic (for constant torque load) 1 : Manual (for variable torque load) 2 : Manual (for proportional torque load) 3 : Manual (for constant torque load)	-	0
	R06	Electronic thermal overload relay for motor 2 (Select)	0 : Inactive 1 : Active (for 4-pole standard motor) 2 : Active (for 4-pole inverter motor)	-	1
	R07	(Level)	Approx. 20 to 135% of rated current	0.01A	*1)
	R08	(Thermal time constant)	0.5 to 10.0 min	0.1min	5.0
	R09	Torque vector control 2	0 : Inactive 1 : Active	-	0
	R10	Number of motor 2 poles	2 to 14	2	4
	R11	Motor 2 (Capacity)	0.01 to 11.00 kw	0.01kW	*1)
	R12	(Rated current)	0.00 to 99.9 A	0.01A	*1)
	R13	(Tuning)	0 : Inactive 1 : Active (One time tuning of %R1 and %X (on motor stopping mode)) 2 : Active (One time tuning of %R1, %X and I _o (on motor running mode))	-	0
	R14	(On-line Tuning)	0 : Inactive 1 : Active (Real time tuning of %R1 and %X)	-	0
	R15	(No-load current)	0.00 to 99.9 A	0.01A	*1)
	R16	(%R1 setting)	0.00 to 50.00 %	0.01%	*1)
	R17	(%X setting)	0.00 to 50.00 %	0.01%	*1)
	R18	Slip compensation control 2	0.00 to +15.00 Hz	0.01Hz	0.00
	R19	(Slip compensation response time)	0.01 to 10.00 s	0.01s	0.5

Function	Description		LED monitor
Overcurrent protection (Short-circuit) (Ground fault)	<ul style="list-style-type: none"> Stops running to protect inverter from an overcurrent resulting from overload. Stops running to protect inverter from an overcurrent due to a short-circuit in the output circuit. Stops running to protect inverter from an overcurrent due to a ground fault in the output circuit. 		During acceleration OC1
			During deceleration OC2
			While running at constant speed OC3
Overvoltage protection	<ul style="list-style-type: none"> The inverter stops when it detects an overvoltage in the DC link circuit. 	<ul style="list-style-type: none"> 400V series : 800V DC or more 200V series : 400V DC or more Protection is not assured if excess AC line voltage is applied inadvertently. 	During acceleration OU1
			During deceleration OU2
			While running at constant speed OU3
Incoming surge protection	<ul style="list-style-type: none"> Protects the inverter against surge voltage between the main circuit power line and ground. Protects the inverter against surge voltage in the main circuit power line. 	<ul style="list-style-type: none"> The inverter may be tripped by some other protective function. 	
Undervoltage protection	<ul style="list-style-type: none"> Stops the inverter when the DC link circuit voltage drops below undervoltage level. 	<ul style="list-style-type: none"> 400V series : 400V DC or less 200V series : 200V DC or less 	LU
Input phase loss protection	<ul style="list-style-type: none"> The inverter is protected from being damaged when open-phase fault occurs. 		Lin
Overheat protection	<ul style="list-style-type: none"> Stops the inverter when it detects excess heat sink temperature in case of cooling fan failure or overload. 		OH1
	<ul style="list-style-type: none"> When the external braking resistor overheats, the inverter stops discharging and running. 		dbH
Electronic thermal overload relay (Motor protection)	<ul style="list-style-type: none"> This function stops the inverter by detecting an inverter overload. This function stops the inverter by detecting an overload in a standard motor or inverter motor. 		OLU
			Motor 1 overload OL1
			Motor 2 overload OL2
Stall prevention (Momentary overcurrent limitation)	<ul style="list-style-type: none"> When an output current exceeds the limit during acceleration, this function lowers output frequency to prevent the occurrence of an OC1 trip. 	<ul style="list-style-type: none"> The stall prevention function can be disabled. 	
External alarm input	<ul style="list-style-type: none"> The inverter stops on receiving external alarm signals. 	<ul style="list-style-type: none"> Use THR terminal function (digital input). 	OH2
Alarm output (for any fault)	<ul style="list-style-type: none"> The inverter outputs a relay contact signal when the inverter issued an alarm and stopped. 	<ul style="list-style-type: none"> Output terminals: 30A, 30B, and 30C Use the RST terminal function for signal input. 	
Alarm reset command	<ul style="list-style-type: none"> An alarm-stop state of the inverter can be cleared with the RESET key or by a digital input signal (RST). 	<ul style="list-style-type: none"> Even if main power input is turned off, alarm history and trip-cause data are retained. 	
Alarm history memory	<ul style="list-style-type: none"> Stores up to four instances of previous alarm data. 		
Storage of data on cause of trip	<ul style="list-style-type: none"> The inverter can store and display details of the latest alarm history data. 		
Memory error	<ul style="list-style-type: none"> The inverter checks memory data after power-on and when the data is written. If a memory error is detected, the inverter stops. 		Er1
KEYPAD panel communication error	<ul style="list-style-type: none"> If an error is detected in communication between the inverter and KEYPAD when the Keypad panel is being used, the inverter stops. 	<ul style="list-style-type: none"> When operated by external signals, the inverter continues running. The alarm output (for any fault) is not output. Only Er2 is displayed. 	Er2
CPU error	<ul style="list-style-type: none"> If the inverter detects a CPU error caused by noise or some other factor, the inverter stops. 		Er3
Option communication error	<ul style="list-style-type: none"> If a checksum error or disconnection is detected during communication, the inverter issues an alarm. 		Er4
Option error	<ul style="list-style-type: none"> If a linkage error or other option error is detected, the inverter issues an alarm. 		Er5
Output phase loss error	<ul style="list-style-type: none"> If an unbalance of output circuits is detected during tuning, this function issues an alarm (and stops the inverter). 		Er7
RS485 communication error	<ul style="list-style-type: none"> If an RS485 communication error is detected, the inverter issues an alarm. 		Er8

NOTES :

1)Retaining alarm signal when auxiliary controll power supply is not used :

If the inverter power supply is cut off while an internal alarm signal is being output, the alarm signal cannot be retained.

2)To issue the RESET command, press the  key on the KEYPAD panel or connect terminals RST and CM once and disconnect them afterwards.

3)Fault history data is stored for the past four trips.

External Dimensions

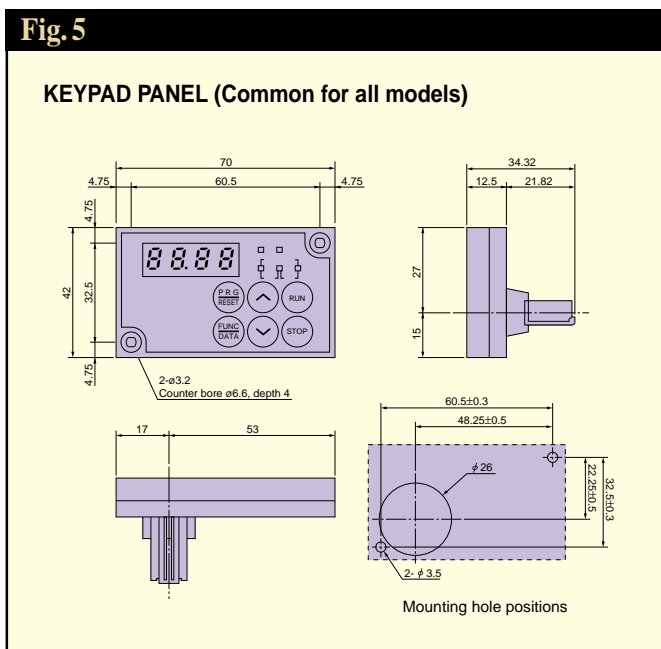
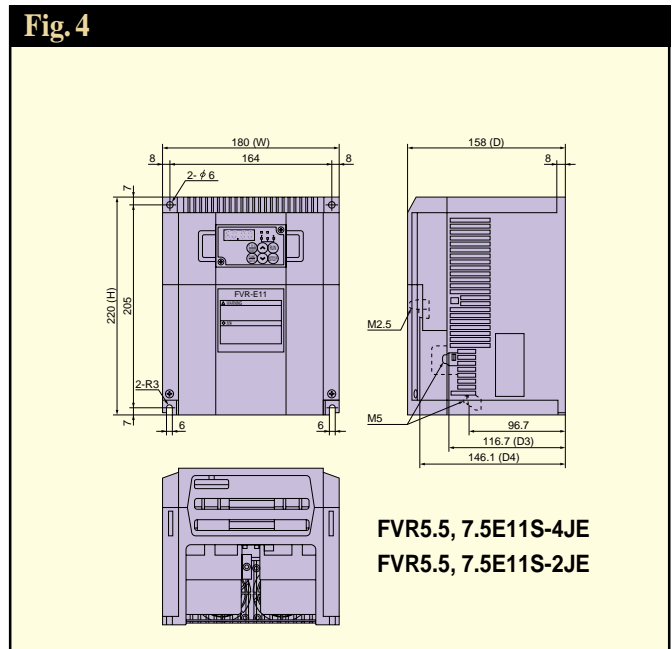
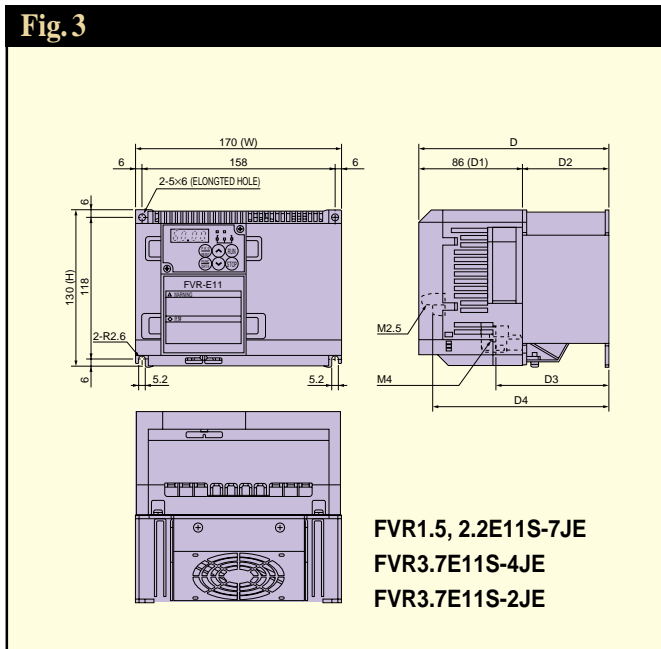
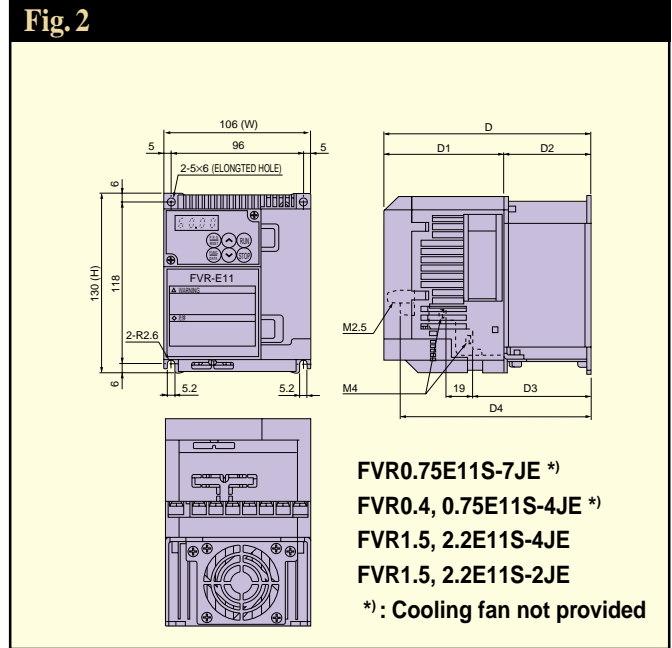
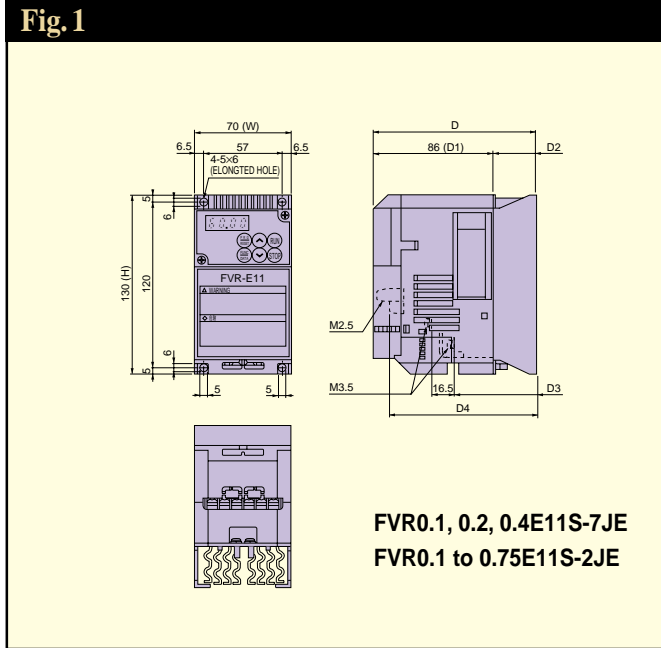



Power supply voltage	Nominal applied motor(kW)	Type	Dimensions(mm)						Fig.	
			W	H	D	D1	D2	D3		D4
1-phase 200V	0.1	FVR0.1E11S-7JE	70	130	96	86	10	38.2	85.2	1
	0.2	FVR0.2E11S-7JE	70	130	101	86	15	43.2	90.2	1
	0.4	FVR0.4E11S-7JE	70	130	118	86	32	60.2	107	1
	0.75	FVR0.75E11S-7JE	106	130	126	86	40	62.5	115	2
	1.5	FVR1.5E11S-7JE	170	130	158	86	72	94.5	147	3
3-phase 400V	2.2	FVR2.2E11S-7JE	170	130	158	86	72	94.5	147	3
	0.4	FVR0.4E11S-4JE	106	130	126	86	40	62.5	115	2
	0.75	FVR0.75E11S-4JE	106	130	150	86	64	86.5	139	2
	1.5	FVR1.5E11S-4JE	106	130	170	106	64	86.5	159	2
	2.2	FVR2.2E11S-4JE	106	130	170	106	64	86.5	159	2
	3.7	FVR3.7E11S-4JE	170	130	158	86	72	94.5	147	3
	5.5	FVR5.5E11S-4JE	180	220	158	-	-	117	146	4
3-phase 200V	7.5	FVR7.5E11S-4JE	180	220	158	-	-	117	146	4
	0.1	FVR0.1E11S-2JE	70	130	96	86	10	38.2	85.2	1
	0.2	FVR0.2E11S-2JE	70	130	101	86	15	43.2	90.2	1
	0.4	FVR0.4E11S-2JE	70	130	118	86	32	60.2	107	1
	0.75	FVR0.75E11S-2JE	70	130	144	86	58	86.2	133	1
	1.5	FVR1.5E11S-2JE	106	130	150	86	64	86.5	139	2
	2.2	FVR2.2E11S-2JE	106	130	150	86	64	86.5	139	2
	3.7	FVR3.7E11S-2JE	170	130	158	86	72	94.5	147	3
	5.5	FVR5.5E11S-2JE	180	220	158	-	-	117	146	4
	7.5	FVR7.5E11S-2JE	180	220	158	-	-	117	146	4

Reactor, Filter, and Other Accessories

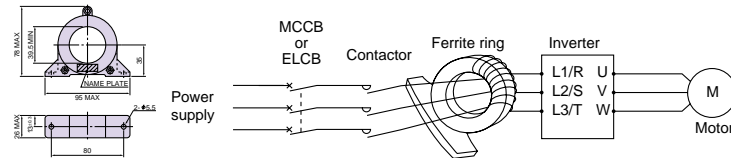
Name (Type)	Function	Mounting position
Arrester (CN23232) (CN2324E)	Suppresses induced lightning surges from power source, thus protecting all equipment connected the power source.	
Ferrite ring for reducing radio noise (ACL-40B)	Reduces radio frequency noise. If the wiring between motor and inverter is shorter than 20m, use the ferrite ring in the power supply side. If longer than 20m, use it in the output side.	
Power filter (FHF-TA/□□/250) (FHF-TA/□□/500)	Prevents the noise generated from the inverter.	
EMC compliance filter (EFL-□□□E11-7) (EFL-□□□E11-4) (EFL-□□□E11-2)	This is a special filter which complies with the European EMC (Emission) Directive. This filter should be used together with a ferrite core. <i>Note: Other prerequisites must be fulfilled to ensure compliance with EMC Directives. Refer to this filters operation manual for details.</i>	
Output circuit filter (OFL-□□□□□) (OFL-□□□□□4A)	Connected to the output circuit of inverters under low-noise operation with carrier frequency from 8 to 15kHz, this filter has the following functions: ① Suppressing fluctuation of motor terminal voltage. Protects the motor insulation from being damaged by surge voltage. (400V series) ② Suppressing leakage current from output side wiring. Reduces the leakage current caused when several motors are operated in parallel or connected with long wiring. * Total wiring length should be less than 400m. ③ Suppressing radial noise or inductive noise from output side wiring. Effective noise suppression device for long wiring applications such as plant. <i>Note: When connecting OFL-□□□□□, be sure to set the carrier frequency F26 at 8kHz or over.</i>	
DC REACTOR(DCR) (DCR4-□□□) (DCR2-□□□)	[Use the DCR to normalize the power supply in the following cases.] ① The power transformer capacity is 500kVA or over and exceeds the inverter rated capacity by 10 times. ② The inverter and a thyristor converter are connected with the same transformer. * Check if the thyristor converter uses a commutation reactor. If not, AC reactor must be connected to the power supply side. ③ Overvoltage trip occurs due to open/close of the phase-advancing capacitor for the power supply lines. ④ The voltage unbalance exceeds 2%. $\text{Voltage unbalance (\%)} = \frac{\text{Max. voltage [V]} - \text{Min. Voltage [V]}}{\text{Three-phase average voltage [V]}} \times 67$ (IEC 61800-3 (5.2.3)) [For improving input power-factor, reducing harmonics] • Used to reduce input harmonic current (correcting power-factor)	
Surge absorber (Surge suppressor) (S2-A-0) (S1-B-0)	S2-A-0: for magnetic contactor S1-B-0: for mini control relay, or timer	
Frequency meter (TRM-45) (FM-60)	Analog frequency meter TRM-45: 45mm square FM-60: 60mm square	
Frequency setting device (RJ-13)	Frequency setting potentiometer (mounted externally)	
Copy unit (CP-E11S)	For batch data transfer (read, store, write) between an inverter unit and the copy unit	

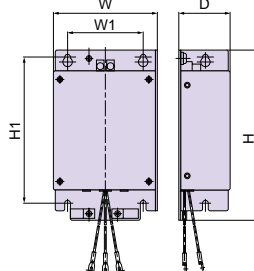
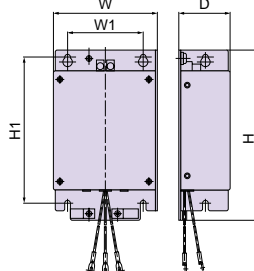
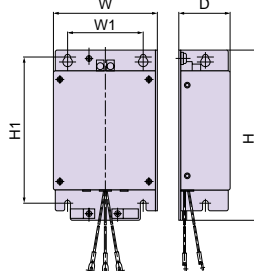
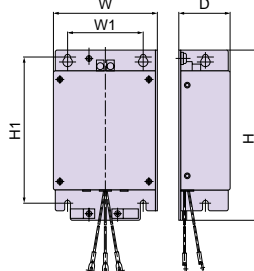
Name (Type)	Dimension	[Unit: mm]		
Ferrite ring for reducing radio noise (ACL-40B) 		Q'ty	No. of turns	Recommended wire size [mm²]
		1	4	2.0, 3.5, 5.5
		2	2	8, 14

EMC Compliance Filter (EFL-□□E11-□)		Power supply voltage	Nominal applied motor [kW]	Inverter type	Filter Type	Rated voltage [V]	Rated current [A]	Leakage current [mA]	Dimensions [mm]					Mass [kg]
									W	W1	H	H1	D	
Single-phase 200V*		0.1 to 0.4	0.75	FVR0.1 to 0.4E11S-7JE	EFL-0.4E11-7	200	6.5	21	71	55	189	178	36	0.5
				FVR0.75E11S-7JE	EFL-0.75E11-7				110	80	191	165	36	0.8
				1.5, 2.2	FVR1.5, 2.2E11S-7JE	EFL-2.2E11-7	240	29	21	174	145	191	165	41
Three-phase 400V*		0.4 to 0.75	1.5, 2.2	FVR0.4 to 0.75E11S-4JE	EFL-0.75E11-4	380	5	12	110	80	191	165	41	0.8
				FVR1.5, 2.2E11S-4JE	EFL-2.2E11-4				110	80	191	165	41	1.0
				3.7	FVR3.7E11S-4JE	EFL-4.0E11-4	480	15	12	174	145	191	165	46
Three-phase 200V		0.1 to 0.75	1.5 to 3.7	FVR0.1 to 0.75E11S-2	EFL-0.75E11-2	200	6.5	3.0	75	60	135	122.5	60	0.5
				FVR1.5 to 3.7E11S-2	EFL-4.0E11-2				80	158	130	80	1.1	
				5.5, 7.5	FVR5.5, 7.5E11S-2	EFL-7.5E11-2	240	53	11	137	100	200	170	115

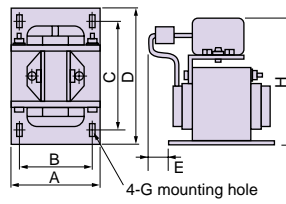
DC REACTOR (DCR-□□□)	External dimensions	Applicable inverter		Reactor type	Dimensions								Terminal hole dia.	Mass [kg]	
		Single-phase 200V series	Three-phase 200V series		A	B	C	D	E	G	H				
		FVR0.1E11S-7JE	FVR0.1, 0.2E11S-2JE	DCR2-0.2	66	56	72	90	5	5.2 × 8	94	M4	0.8		
		FVR0.2E11S-7JE	FVR0.4E11S-2JE	DCR2-0.4	66	56	72	90	15	5.2 × 8	94	M4	1.0		
		FVR0.4E11S-7JE	FVR0.75E11S-2JE	DCR2-0.75	66	56	72	90	20	5.2 × 8	94	M4	1.4		
		FVR0.75E11S-7JE	FVR1.5E11S-2JE	DCR2-1.5	66	56	72	90	20	5.2 × 8	94	M4	1.6		
		FVR1.5E11S-7JE	FVR2.2E11S-2JE	DCR2-2.2	86	71	80	100	10	6 × 11	110	M4	1.8		
		FVR2.2E11S-7JE	FVR3.7E11S-2JE	DCR2-3.7	86	71	80	100	20	6 × 11	110	M4	2.6		
		—	FVR5.5E11S-2JE	DCR2-5.5	111	95	80	100	20	7 × 11	130	M5	3.6		
		—	FVR7.5E11S-2JE	DCR2-7.5	111	95	80	100	23	7 × 11	130	M5	3.8		
		Three-phase 400V series													
		FVR0.4E11S-4JE		DCR4-0.4	66	56	72	90	15	5.2 × 8	94	M4	1.0		
FVR0.75E11S-4JE		DCR4-0.75	66	56	72	90	20	5.2 × 8	94	M4	1.4				
FVR1.5E11S-4JE		DCR4-1.5	66	56	72	90	20	5.2 × 8	94	M4	1.6				
FVR2.2E11S-4JE		DCR4-2.2	86	71	80	100	15	6 × 9	110	M4	2.0				
FVR3.7E11S-4JE		DCR4-3.7	86	71	80	100	20	6 × 9	110	M4	2.6				
FVR5.5E11S-4JE		DCR4-5.5	86	71	80	100	20	6 × 9	110	M4	2.6				
FVR7.5E11S-4JE		DCR4-7.5	111	95	80	100	24	7 × 11	130	M5	4.2				

Wiring equipment

Power supply voltage	Nominal applied motor [kW]	Inverter type	MCCB or ELCB Rated current [A]		Magnetic contactor (MC)			Recommended wire size [mm ²]					
			With DCR	Without reactor	Input circuit		Output circuit	Input circuit [L1/R, L2/S, L3/T]		Output circuit [U, V, W]	DCR circuit [P1, P(+)]	DB circuit [P(+), DB, N(-)]	
					With DCR	Without reactor		With DCR	Without reactor				
Single-phase 200V	0.1, 0.2	FVR0.1, 0.2E11S-7JE	5	5	SC-05	SC-05	SC-05	2.0	2.0	2.0	2.0	2.0	
	0.4	FVR0.4E11S-7JE		10									15
	0.75	FVR0.75E11S-7JE		15									20
	1.5	FVR1.5E11S-7JE		20									30
	2.2	FVR2.2E11S-7JE		30									40
Three-phase 400V	0.4, 0.75	FVR0.4, 0.75E11S-4JE	5	5	SC-05	SC-05	SC-05	2.0	2.0	2.0	2.0	2.0	
	1.5	FVR1.5E11S-4JE		10									15
	2.2	FVR2.2E11S-4JE		15									20
	3.7	FVR3.7E11S-4JE		20									30
	5.5	FVR5.5E11S-4JE		30									40
Three-phase 200V	0.1 to 0.4	FVR0.1 to 0.4E11S-2JE	5	5	SC-05	SC-05	SC-05	2.0	2.0	2.0	2.0	2.0	
	0.75	FVR0.75E11S-2JE		10									15
	1.5	FVR1.5E11S-2JE		15									20
	2.2	FVR2.2E11S-2JE		20									30
	3.7	FVR3.7E11S-2JE		30									40
	5.5	FVR5.5E11S-2JE		40									50
	7.5	FVR7.5E11S-2JE		50									75

NOTES :

- For molded-case circuit breakers (MCCB) and earth-leakage circuit breakers (ELCB), the required frame type and series depend on the facility transformer capacity and other factors. When selecting optimal breakers, refer to the relevant technical data. • Also select the rated sensitive current of ELCB utilizing the technical data.
- The recommended wire sizes are based on the condition that the temperature inside the panel does not exceeds 50°C. • The above wires are 600V HIV insulated cables (75°C). • Data in the above table may differ for different conditions (ambient temperature, power supply voltage, and other factors).

Name (type) **Functions and dimensions** **[Unit : mm]**

Braking resistor
 [Standard type]
 (DB□□□-□)
 [10%ED type]
 (DB□□□-□C)

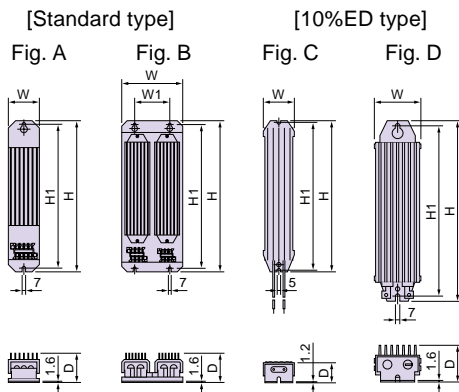

	Type		Fig.	Dimensions [mm]					Mass [kg]
	200V	400V		W	W1	H	H1	D	
Standard type	DB0.75-2	DB0.75-4	A	64	-	310	295	67	1.3
	DB2.2-2	-	A	76	-	345	332	94	2.0
	-	DB2.2-4	A	64	-	470	455	67	2.0
	DB3.7-2	-	A	76	-	345	332	94	2.0
	-	DB3.7-4	A	64	-	470	455	67	1.7
	DB5.5-2	-	B	142	90	450	430	67.5	4.5
	-	DB5.5-4	B	142	74	470	455	67	4.5
	DB7.5-2	-	B	156	90	390	370	90	5.0
10%ED type	-	DB7.5-4	B	142	74	520	495	67	5.0
	DB0.75-2C	DB0.75-4C	C	43	-	221	215	30.5	0.5
	DB2.2-2C	DB2.2-4C	D	67	-	188	172	55	0.8
	DB3.7-2C	DB3.7-4C	D	67	-	328	312	55	1.6
	DB5.5-2C	DB5.5-4C	D	80	-	378	362	78	2.9
DB7.5-2C	DB7.5-4C	D	80	-	418	402	78	3.3	

Series	Applicable inverter	FVR0.4 E11S-4JE	FVR0.75 E11S-4JE	FVR1.5 E11S-4JE	FVR2.2 E11S-4JE	FVR3.7 E11S-4JE	FVR5.5 E11S-4JE	FVR7.5 E11S-4JE	
400V	Applied motor output [kW]	0.4	0.75	1.5	2.2	3.7	5.5	7.5	
	Braking unit	Unnecessary							
	Average braking torque [%]	150	150	150	150	150	150	150	
	Standard type	Type	DB0.75-4		DB2.2-4		DB3.7-4	DB5.5-4	DB7.5-4
		Resistor capacity [kW]	0.2		0.4		0.4	0.8	0.9
		Ohmic value [Ω]	200		160		130	80	60
		Allowable duty cycle [%]	22	18	10	7	5	5	5
		Continuous allowable braking time	45s	45s	45s	30s	20s	20s	10s
	10%ED type	Type	DB0.75-4C		DB2.2-4C		DB3.7-4C	DB5.5-4C	DB7.5-4C
		Resistor capacity [kW]	0.2		0.4		0.4	0.8	0.9
		Ohmic value [Ω]	200		160		130	80	60
		Allowable duty cycle [%]	10	10	10	10	10	10	10
Continuous allowable braking time		45s	45s	45s	30s	20s	20s	10s	

Series	Applicable inverter	FVR0.1 E11S-2JE	FVR0.2 E11S-2JE	FVR0.4 E11S-2JE	FVR0.75 E11S-2JE	FVR1.5 E11S-2JE	FVR2.2 E11S-2JE	FVR3.7 E11S-2JE	FVR5.5 E11S-2JE	FVR7.5 E11S-2JE
200V	Applied motor output [kW]	0.1	0.2	0.4	0.75	1.5	2.2	3.7	5.5	7.5
	Braking unit	Unnecessary								
	Average braking torque [%]	150	150	150	150	150	150	150	150	150
	Standard type	Type	DB0.75-2			DB2.2-2		DB3.7-2	DB5.5-2	DB7.5-2
		Resistor capacity [kW]	0.2			0.4		0.4	0.9	1.4
		Ohmic value [Ω]	100			40		33	20	15
		Allowable duty cycle [%]	25	25	15	12	7	7	5	5
		Continuous allowable braking time	60s	60s	60s	60s	30s	30s	20s	20s
	10%ED type	Type	DB0.75-2C			DB2.2-2C		DB3.7-2C	DB5.5-2C	DB7.5-2C
		Resistor capacity [kW]	0.2			0.4		0.4	0.8	0.9
		Ohmic value [Ω]	100			40		33	20	15
		Allowable duty cycle [%]	10	10	10	10	10	10	10	10
Continuous allowable braking time		90s	90s	45s	45s	45s	30s	20s	20s	10s

Braking resistor
 [Compact type]
 (TK80W120Ω)

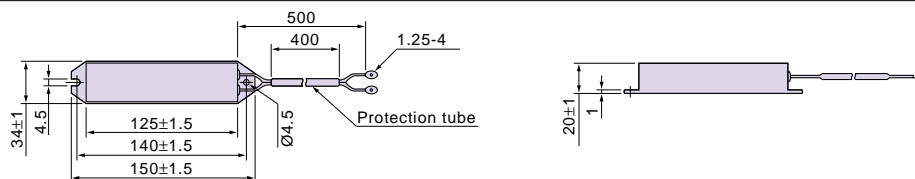

Series	Type	TK80W120Ω								
200V	Resistor	Capacity [kW]	0.08							
		Ohmic value [Ω]	120							
	Applicable inverter	FVR0.1 E11S-2JE	FVR0.2 E11S-2JE	FVR0.4 E11S-2JE	FVR0.75 E11S-2JE	FVR1.5 E11S-2JE	FVR2.2 E11S-2JE	FVR3.7 E11S-2JE		
	Applied motor output [kW]	0.1	0.2	0.4	0.75	1.5	2.2	3.7		
	Average braking torque [%]	150	150	150	130	100	65	45		
	Allowable duty cycle [%]	25	25	15	5	5	5	5		
	Continuous allowable braking time	30s	30s	15s	15s	10s	10s	10s		
	Braking unit	Unnecessary								

NOTE: This resistor is not applicable to 400V series inverter

Extension cable with
 adapter for Keypad
 panel
 (CBR-5S)

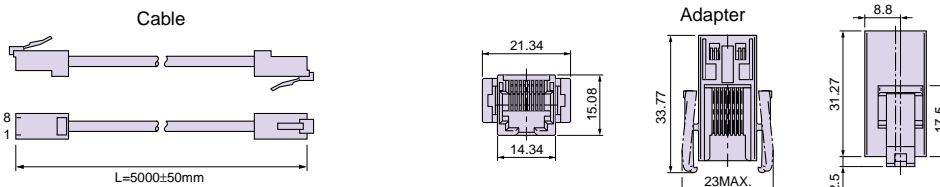



NOTES

Application to standard motors

• Driving a 400V standard motor

When driving a 400V standard motor with an inverter, damage may occur in the insulation of motor. Use the output circuit filter (OFL) if necessary after confirmation with the motor manufacturer. The use of Fuji Electric Motor does not require the output circuit filter because of its reinforced insulation.

• Torque characteristics and temperature rise

When the inverter is used to operate a standard motor, the temperature rises a little higher than during operation by a commercial power supply. The cooling effect decreases in the low-speed range, reducing the allowable output torque. (If a constant torque is required in the low-speed range, use a Fuji inverter motor or a motor equipped with a separately ventilating fan.)

• Vibration

Use of an inverter does not increase vibration of a standard motor, but when the motor is mounted to a machine, resonance may be caused by the natural frequencies including the natural frequency of the machine system.

* We recommend that you use rubber coupling or anti-vibration rubber.

* We also recommend that you use the inverter jump frequency control function to avoid resonance point in the motor operation.

Note that operation of a 2-pole motor at 60Hz or over may cause abnormal vibration.

• Noise

When an inverter drives a standard motor, the motor noise level increases compared with driven by a commercial power supply. To reduce noise, set the inverter carrier frequency at a high level. High-speed operation at 60Hz or over can result in more noise.

Application to special motors

• Explosion-proof motors

When driving an explosion-proof motor with an inverter, use a combination of a motor and an inverter that has been approved in advance. Such approved products are available in our special product series. Contact Fuji for details.

• Submersible motors and pumps

These motors have a larger rated current than standard motors. Select the inverter capacity so that these motors can run within the inverter rated current. These motors differ from standard motors in thermal characteristics. Set a small value according to the thermal time constant of motor for setting electronic thermal relay function.

• Brake motors

For motors with parallel-connection brakes, obtain the brake power from the primary circuit (commercial power supply). If you connect the brake power to the inverter power output circuit by mistake, problems may occur. Do not use inverters for driving motors equipped with series-connection brakes.

• Geared motors

When the power transmission mechanism uses an oil-lubricated gearbox or speed changer/reducer, continuous motor operation at low speed may cause poor lubrication.

• Synchronous motors

It is necessary to use software suitable for the motor type.

Contact Fuji for details.

• Single-phase motors

Single-phase motors are not suitable for inverter-driven variable speed operation. Use three-phase motors.

* Even if a single-phase power supply is available, use a three-phase motor, because the inverter provides three-phase output.

Combination with peripheral device

• Installation location

Use the inverter in an ambient temperature range between -10 to 50°C.

The inverter and braking resistor surfaces become hot under certain operating conditions. Install an inverter on non-flammable material.

• Installing Fuji Auto Breaker (MCCB)

Install a Fuji Auto Breaker (MCCB) or earth-leakage circuit breaker in the primary circuit of the inverter to protect wires.

• Magnetic contactor in the secondary circuit

If a magnetic contactor is mounted in the secondary circuit for switching to the motor operation by commercial power supply or for any other purposes, ensure that the inverter and the motor are stopped before you turn on or off the contactor.

• Magnetic contactor in the primary circuit

Do not open or close the magnetic contactor in the primary circuit more than once an hour. If frequent starts or stops are required during motor operation, send FWD or REV signals to the control terminal.

• Protecting the motor

When you drive a motor with an inverter, the motor can be protected with an electronic thermal relay function of the inverter. In addition to the operation level, set the motor type (standard motor, inverter motor). For high-speed motors or water-cooled motors, set a small value as the thermal time constant and protect the motor in combination with the "cooling system OFF" signal. When driving several motors with an inverter, connect a thermal relay to each motor and turn on the inverter's electronic thermal relay function. If you connect the motor thermal relay to the motor with a long cable, high-frequency current may flow into the wiring floating capacity. This may cause the relay to trip at a current lower than the set value for the thermal relay. If this happens, lower the carrier frequency or use the output circuit filter (OFL).

• Power-factor correcting capacitor

Do not mount the power-factor correcting capacitor in the inverter primary circuit. (Use the DC reactor to improve the inverter power factor.) Do not use the power-factor correcting capacitor in the inverter secondary circuit. Overcurrent trip will occur, disabling motor operation.

• Reducing noise

Use of filter and shielded wires are typical measures against noise that meets EMC Directives. For details, refer to the operation procedure manual.

• Measures against surge current

If OV trip occurs while the inverter is stopped or operated under a light load, it is assumed that the surge current is generated by open/close of the phase-advancing capacitor in the power system.

* Connect a DC reactor to the inverter.

• Megger test

When checking insulation resistance of the inverter, use a 500V megger and follow the instructions described in the instruction manual.

Wiring

• Control circuit wiring length

When conducting a remote control, limit the wiring length between the inverter and operator box to 20m or less and use twisted shielded cable.

• Wiring length between inverter and motor

If long wiring is used between the inverter and the motor, the inverter will overheat or trip because of overcurrent (under the influence of high-frequency current flowing into the floating capacity) in the wires connected to the phases. Ensure that the wiring is shorter than 50m for models 3.7kW or smaller, shorter than 100m for 5.5kW or larger. If these lengths must be exceeded, lower the carrier frequency or mount an output circuit filter (OFL). When wiring is longer than 50m, and Dynamic torque-vector control is selected, execute off-line tuning.

• Wiring size

Select a cable with a sufficient capacity by referring to the current value or recommended wire size.

• Grounding

Securely ground the inverter using the grounding terminal.

Selecting inverter capacity

• Driving standard motor

Select an inverter from the capacity range of nominal applied motors shown in the inverter standard specifications table. When large starting torque is required or acceleration or deceleration is required in a short time, select an inverter with a capacity one class greater than the standard.

• Driving special motor

Select an inverter that meets the following condition: Inverter rated current > Motor rated current

Transportation, storage

When transporting or storing inverters, select the procedures and places that meet the environmental conditions given in the inverter specifications. Ensure that the above environmental conditions are met also when transporting an inverter mounted to a machine.

Fuji Electric Co., Ltd.

ED&C · Drive Systems Company

Gate City Ohsaki, East Tower, 11-2, Osaki 1-chome

Shinagawa-ku, Tokyo 141-0032, Japan

Phone: +81-3-5435-7139 Fax: +81-3-5435-7460



Printed on 100% recycled paper